



MLZ / MLM Refrigeration scroll compressors

50 - 60 Hz - R404A - R507 - R134a - R22

FEATURES.....	4
SCROLL COMPRESSION PRINCIPLE.....	5
The scroll compression process.....	5
COMPRESSOR MODEL DESIGNATION.....	6
Nomenclature.....	6
Label.....	6
TECHNICAL SPECIFICATIONS.....	7
50 Hz.....	8
60 Hz.....	9
DIMENSIONS.....	10
MLZ/MLM015-019-021-026.....	10
MLZ/MLM030-038-045-048.....	11
MLZ/MLM058-066-076.....	12
Oil sight glass.....	13
Schrader.....	13
Suction and discharge connections.....	13
ELECTRICAL DATA, CONNECTIONS AND WIRING.....	14
Motor voltage.....	14
Wiring connections.....	14
IP rating.....	14
Three phase electrical characteristics.....	15
Single phase electrical characteristics.....	15
LRA (Locked Rotor Amp).....	15
MCC (Maximum Continuous Current).....	15
Max Oper. A (Maximum Operating Amp).....	15
Winding resistance.....	16
Electrical connections.....	16
Nominal capacitor value and relays.....	17
Three phase.....	17
Internal motor protection.....	18
Phase sequence and reverse rotation protection.....	18
Voltage imbalance.....	18
APPROVALS AND CERTIFICATIONS.....	19
Approvals and certificates.....	19
Conformity to directives.....	19
Internal free volume.....	19
OPERATING CONDITIONS.....	20
Refrigerant and lubricants.....	20
Motor supply.....	21
Compressor ambient temperature.....	21
Application envelope.....	21
Maximum discharge gas temperature.....	23
High and low pressure protection.....	24
On/off cycling (cycle rate limit).....	24
SYSTEM DESIGN RECOMMENDATIONS.....	25
General.....	25
Essential piping design considerations.....	25
Refrigerant charge limit.....	26
Off-cycle migration.....	26
Liquid flood back.....	28

SPECIFIC APPLICATION RECOMMENDATIONS 29

- Low ambient application 29
- Scroll and reciprocating 29
- Low load operations 30
- Brazed plate heat exchangers 30
- Water utilising systems 30

SOUND AND VIBRATION MANAGEMENT 31

- Starting sound level 31
- Running sound level 31
- Stopping sound level 31
- Sound generation in a refrigeration system 31
- Compressor sound radiation 31
- Mechanical vibrations 32
- Gas pulsation 32

INSTALLATION 33

- System cleanliness 33
- Compressor handling and storage 33
- Compressor mounting 33
- Compressor holding charge 33
- Tube brazing procedure 33
- Brazing material 33
- Vacuum evacuation and moisture removal 34
- Liquid line filter driers 35
- Refrigerant charging 35
- Insulation resistance and dielectric strength 35

ORDERING INFORMATION AND PACKAGING 36

- Packaging 36
- Packaging details 36

SPARE PARTS & ACCESSORIES 38

- Run capacitors for PSC wiring 38
- Start capacitors and starting relay for CSR wiring 38
- Rotolock adaptor set 38
- Rotolock adaptor 38
- Crankcase heater 39
- Discharge temperature protection 39
- Lubricant 39
- Mounting hardware 39

With its unique scroll design and manufacturing process flexibility, the new Danfoss MLZ/MLM refrigeration compressor offers a highly efficient solution for demanding refrigeration applications.

This new family of refrigeration compressors includes 11 sizes of medium temperature scroll com-

pressors designed for commercial refrigeration applications. These compressors are engineered for refrigeration, and offer cooling capacity from 3.4 to 21 kW (2 to 10 HP) at common voltages and frequencies as well as any of the common refrigerants (R404A - R134a - R507 - R22).

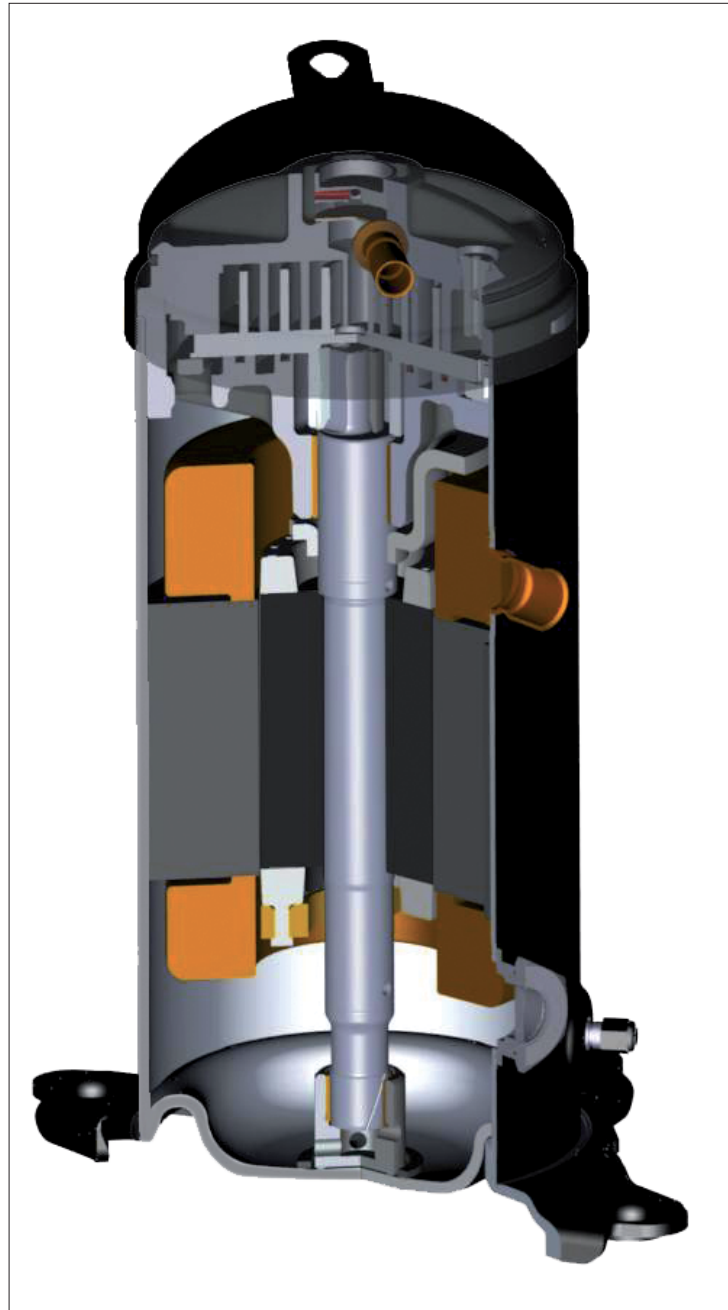

Thanks to its dedicated refrigeration design, the MLZ/MLM scroll compressor delivers a number of powerful advantages. With its high efficiency motor and optimised scroll design it reduces energy

cost in normal operating conditions and delivers high capacity and an optimised pressure ratio for refrigeration applications.

The scroll compression process

The entire scroll compression process is illustrated below. The centre of the orbiting scroll traces a circular path around the centre of the fixed scroll. This movement creates compression pockets between the two scroll elements.

Low pressure suction gas is trapped within each crescent-shaped pocket as it forms; continuous motion of the orbiting scroll serves to seal the pocket, which decreases in volume as the pocket

moves towards the centre of the scroll set, with corresponding increase in gas pressure. Maximum compression is achieved, as the pocket reaches the discharge port at the centre.

Scroll compression is a continuous process: when one pocket of gas is being compressed during the second orbit, another gas quantity enters a new pocket formed at the periphery, and simultaneously, another is being discharged.

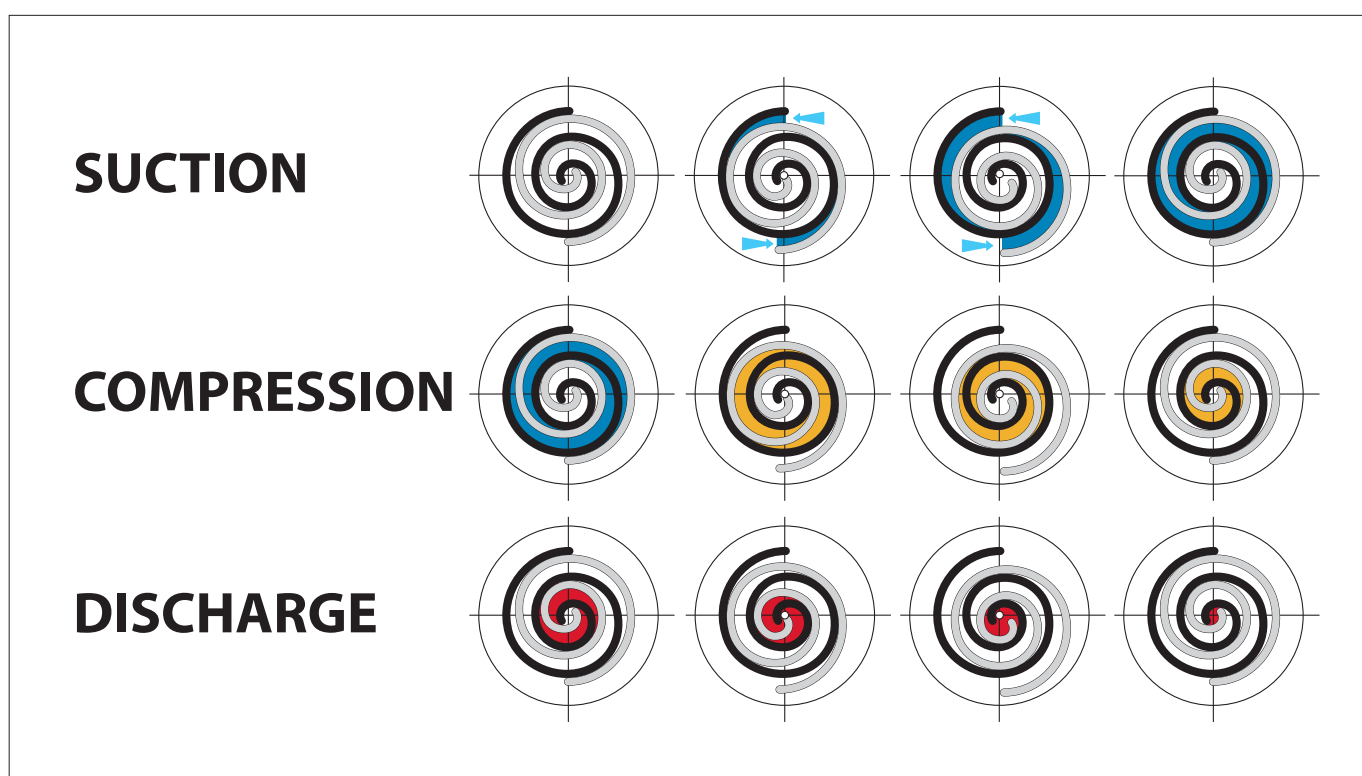

Danfoss scroll compressors are manufactured using the most advanced machining, assembly, and process control techniques. In design of both the compressor and the factory, very high standards

of reliability and process control were first priority. The result is a highly efficient product with the highest reliability obtainable, and a low sound level.

Nomenclature

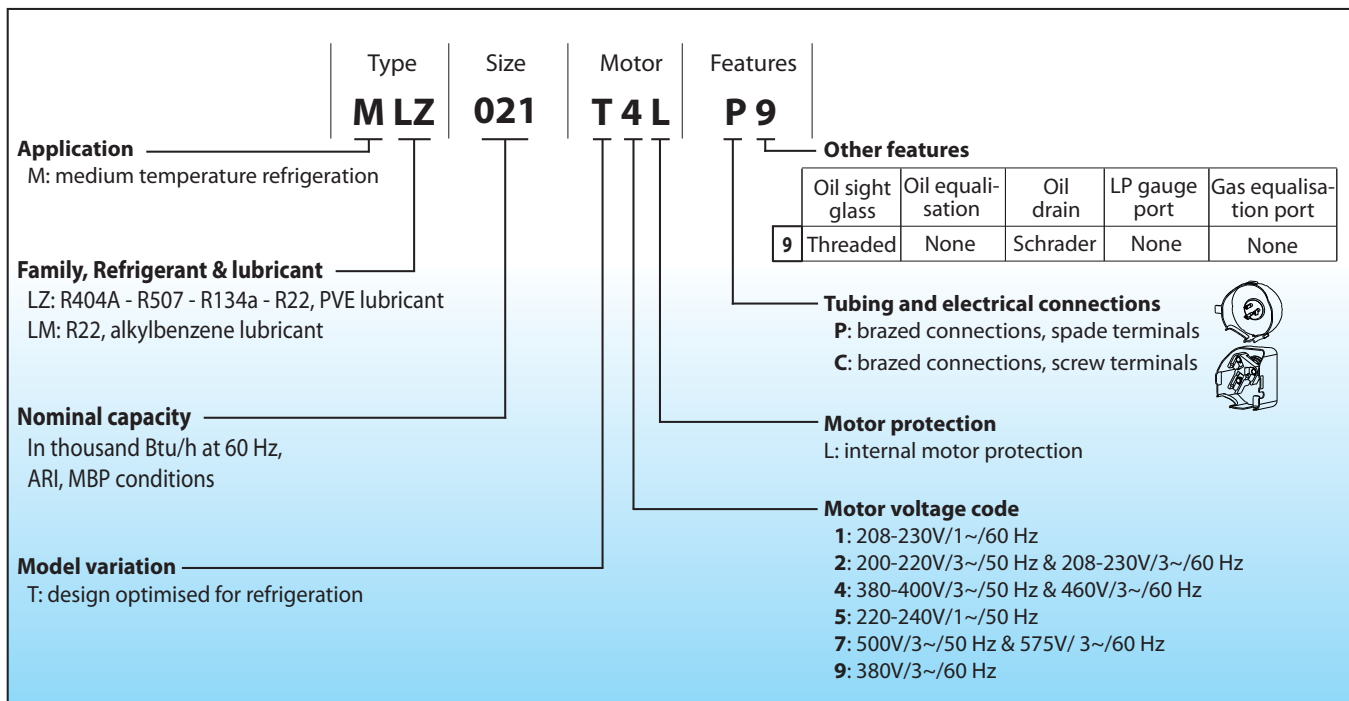

Label

Danfoss Commercial Compressors

Model no MLZ038T4LC9

380-400 V 3 ~ 50 Hz
460 V 3 ~ 60 Hz
Run Cap: NA
LRA: 70.0 Max Oper A: 11.4
LUBRICANT: PVE - 53 oz / 1.57 L
REFRIGERANTS: R404A, R134A, R22, R507

Tech no MRH602BF01

Serial no S0309K12345

CE cRU US CCC

2009

THERMALLY PROTECTED PROTECTED BY DOMESTIC AND FOREIGN PATENTS

⚠ WARNING
Refer to service instructions. Disobeying could cause serious injury or death.
1. **ELECTRICAL SHOCK** - Terminal cover must be in place and securely retained whenever power is applied to this compressor. Failure to do so results in hazardous exposure to high voltage and other dangers.
2. **HIGH PRESSURE** - Remove pressure before servicing wearing safety goggles. Use all service points to remove pressure.
3. **FIRE HAZARD** - Do not use torch to remove components oil may catch fire. Use tubing cutter to remove components.

⚠ CAUTION
1. Use copper conductors only.
2. Use 60°C wire for ampacity determination.
3. Terminal connections may vary by manufacturer. To avoid permanent damage, wires must match terminals as identified on inside of terminal box cover and gasket.
4. Use this equipment on a grounded system only.

⚠ AVERTISSEMENT
La réglementation locale en vigueur doit être respectée. Le non respect des instructions de service peut entraîner des blessures graves.
1. **ELECTROCUTION** - La couverture du bornier électrique doit être montée correctement lorsque le compresseur est mis sous tension. Ce couvercle protège des dangers de la borne de raccordement.
2. **HAUTE PRESSION** - Avant d'intervenir sur le circuit, Réduire la pression interne et porter des lunettes de protection.
3. **DANGER D'INCENDIE** - Utiliser un coupe tubes pour ouvrir le circuit frigorifique, l'usage d'un chalumeau risque d'enflammer l'huile du circuit.

⚠ ATTENTION
1. Raccorder le compresseur avec des conducteurs en cuivre.
2. Utiliser un fil dont l'isolation supporte un échauffement de 60°C.
3. Respecter les indications placées à l'intérieur du boîtier pour le raccordement des bornes du compresseur.
4. Il est impératif de relier le compresseur à la terre.

ZZZ0101B

Serial number

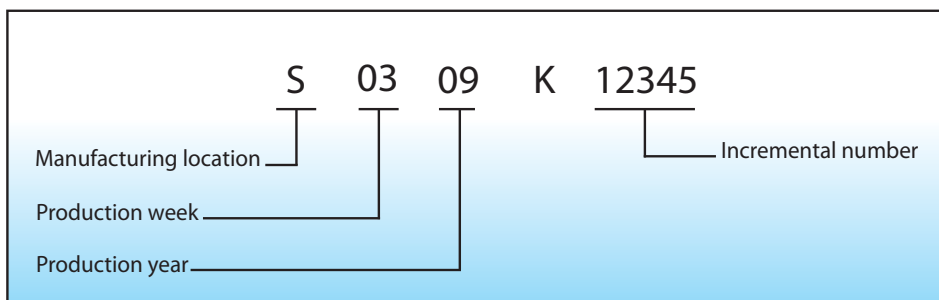

	Model	HP	Nominal cooling capacity *		Power input *	Efficiency *		Swept volume	Displacement	Oil charge	Net weight (with oil)	
			W	Btu/h		COP	EER					
			W	Btu/h	kW	W/W	Btu/h/W	cm ³ /rev	m ³ /h	Litres	kg	
50 HZ	R404A **	MLZ015	2									
		MLZ019	2 ½	4500	15 200	2.16	2.06	7.05	43.5	7.6	1.1	31
		MLZ021	3	4700	16 100	2.27	2.08	7.09	46.2	8.0	1.1	31
		MLZ026	3 ½	5900	20 100	2.83	2.09	7.12	57.1	9.9	1.1	31
		MLZ030	4	7100	24 200	3.34	2.13	7.25	68.8	12.0	1.6	37
		MLZ038	5	8500	28 800	3.97	2.13	7.27	81.0	14.1	1.6	37
		MLZ045	6	10200	34 700	4.59	2.22	7.56	98.6	17.2	1.6	37
		MLZ048	7	11100	37 900	5.05	2.20	7.50	107.5	18.7	1.6	37
		MLZ058	7 ½	12900	43 900	6.22	2.07	7.06	126.0	21.9	2.7	44
		MLZ066	9	15200	51 800	6.92	2.19	7.49	148.8	25.9	2.7	45
	MLZ076	10	17300	59 100	7.93	2.18	7.45	162.4	28.3	2.7	45	
	R134a	MLZ015	2									
		MLZ019	2 ½	2600	9 000	1.28	2.05	7.01	43.5	7.6	1.1	31
		MLZ021	3	2800	9 500	1.33	2.11	7.20	46.2	8.0	1.1	31
		MLZ026	3 ½	3400	11 800	1.62	2.13	7.25	57.1	9.9	1.1	31
		MLZ030	4	4200	14 200	1.93	2.16	7.38	68.8	12.0	1.6	37
		MLZ038	5	4900	16 700	2.34	2.09	7.13	81.0	14.1	1.6	37
		MLZ045	6	6000	20 600	2.69	2.24	7.66	98.6	17.2	1.6	37
		MLZ048	7	6400	21 900	2.91	2.21	7.54	107.5	18.7	1.6	37
		MLZ058	7 ½	7700	26 100	3.61	2.12	7.25	126.0	21.9	2.7	44
		MLZ066	9	8900	30 400	4.10	2.17	7.42	148.8	25.9	2.7	45
	MLZ076	10	9900	33 900	4.67	2.13	7.25	162.4	28.3	2.7	45	
	R22	MLZ/MLM015	2									
		MLZ/MLM019	2 ½	4200	14 400	1.88	2.25	7.68	43.5	7.6	1.1	31
		MLZ/MLM021	3	4500	15 300	2.07	2.16	7.38	46.2	8.0	1.1	31
		MLZ/MLM026	3 ½	5700	19 500	2.39	2.39	8.16	57.1	9.9	1.1	31
		MLZ/MLM030	4	6700	22 800	3.04	2.19	7.48	68.8	12.0	1.6	37
		MLZ/MLM038	5	7800	26 600	3.55	2.20	7.50	81.0	14.1	1.6	37
MLZ/MLM045		6	9900	33 900	4.03	2.47	8.42	98.6	17.2	1.6	37	
MLZ/MLM048		7	10600	36 100	4.42	2.39	8.17	107.5	18.7	1.6	37	
MLZ/MLM058		7 ½	12000	41 100	5.31	2.26	7.73	126.0	21.9	2.7	44	
MLZ/MLM066		9	14400	49 000	5.90	2.43	8.31	148.8	25.9	2.7	45	
MLZ/MLM076	10	16600	56 700	6.71	2.48	8.45	162.4	28.3	2.7	45		
60 HZ	R404A **	MLZ015	2									
		MLZ019	2 ½	5500	18 600	2.58	2.12	7.22	43.5	9.1	1.1	31
		MLZ021	3	5800	19 900	2.74	2.13	7.26	46.2	9.7	1.1	31
		MLZ026	3 ½	7200	24 700	3.44	2.10	7.18	57.1	12.0	1.1	31
		MLZ030	4	8500	29 000	3.90	2.18	7.45	68.8	14.4	1.6	37
		MLZ038	5	10200	34 900	4.70	2.18	7.44	81.0	17.0	1.6	37
		MLZ045	6	12400	42 200	5.64	2.19	7.49	98.6	20.7	1.6	37
		MLZ048	7	13500	46 200	6.15	2.20	7.51	107.5	22.6	1.6	37
		MLZ058	7 ½	15700	53 700	7.35	2.14	7.31	126.0	26.4	2.7	44
		MLZ066	9	18400	62 600	8.40	2.19	7.46	148.8	31.2	2.7	45
	MLZ076	10	20900	71 300	9.59	2.18	7.43	162.4	34.1	2.7	45	
	R134a	MLZ015	2									
		MLZ019	2 ½	3200	11 000	1.53	2.11	7.19	43.5	9.1	1.1	31
		MLZ021	3	3400	11 700	1.58	2.17	7.41	46.2	9.7	1.1	31
		MLZ026	3 ½	4200	14 500	1.91	2.22	7.57	57.1	12.0	1.1	31
		MLZ030	4	5100	17 500	2.35	2.18	7.43	68.8	14.4	1.6	37
		MLZ038	5	6000	20 600	2.80	2.16	7.36	81.0	17.0	1.6	37
		MLZ045	6	7300	25 100	3.32	2.21	7.55	98.6	20.7	1.6	37
		MLZ048	7	7800	26 700	3.54	2.21	7.53	107.5	22.6	1.6	37
		MLZ058	7 ½	9400	32 100	4.28	2.20	7.50	126.0	26.4	2.7	44
		MLZ066	9	10800	36 800	4.85	2.22	7.58	148.8	31.2	2.7	45
	MLZ076	10	12100	41 400	5.61	2.16	7.38	162.4	34.1	2.7	45	
	R22	MLZ/MLM015	2									
		MLZ/MLM019	2 ½	5200	17 700	2.49	2.09	7.12	43.5	9.1	1.1	31
		MLZ/MLM021	3	5700	19 500	2.52	2.26	7.73	46.2	9.7	1.1	31
		MLZ/MLM026	3 ½	7300	24 800	3.01	2.41	8.23	57.1	12.0	1.1	31
		MLZ/MLM030	4	8200	27 900	3.48	2.35	8.02	68.8	14.4	1.6	37
		MLZ/MLM038	5	9800	33 400	4.06	2.41	8.22	81.0	17.0	1.6	37
MLZ/MLM045		6	11800	40 200	4.86	2.43	8.28	98.6	20.7	1.6	37	
MLZ/MLM048		7	12900	44 200	5.36	2.41	8.23	107.5	22.6	1.6	37	
MLZ/MLM058		7 ½	15100	51 500	6.46	2.34	7.97	126.0	26.4	2.7	44	
MLZ/MLM066		9	17500	59 900	7.28	2.41	8.23	148.8	31.2	2.7	45	
MLZ/MLM076	10	20600	70 400	8.59	2.40	8.20	162.4	34.1	2.7	45		

* at EN12900 conditions: T₀ = -10°C, T_c = 45°C, RGT = 20°C, SC = 0K

** R507 performance data are nearly identical to R404A performance data

Motor voltage code 4: 400V/3~/50 Hz & 460V/3~/60 Hz

50 Hz

Models	T _o =-10°C, T _c =40°C RGT=20°C, SC=0K Coldroom		T _o =-6.7°C, T _c =40°C RGT=20°C, SC=0K Ice machine		T _o =0°C, T _c =40°C RGT=20°C, SC=0K Air drier		T _o =-3°C, T _c =45°C RGT=20°C, SC=0K Milk tank		T _o =-10°C, T _c =45°C RGT=20°C, SC=0K EN12900 conditions		
	Capacity W	COP W/W	Capacity W	COP W/W	Capacity W	COP W/W	Capacity W	COP W/W	Capacity W	COP W/W	
R404A *	MLZ015										
	MLZ019	4 800	2.52	5 500	2.85	6 900	3.64	5 700	2.68	4 500	2.06
	MLZ021	5 100	2.53	5 800	2.86	7 300	3.63	6 100	2.68	4 700	2.08
	MLZ026	6 400	2.54	7 200	2.88	9 200	3.67	7 600	2.71	5 900	2.09
	MLZ030	7 700	2.59	8 700	2.93	11 100	3.72	9 200	2.75	7 100	2.13
	MLZ038	9 200	2.59	10 400	2.92	13 200	3.68	10 900	2.73	8 500	2.13
	MLZ045	11 100	2.70	12 500	3.05	15 900	3.86	13 100	2.86	10 200	2.22
	MLZ048	12 100	2.68	13 600	3.03	17 300	3.85	14 300	2.84	11 100	2.20
	MLZ058	14 300	2.57	16 300	2.93	20 900	3.75	17 000	2.75	12 900	2.07
	MLZ066	16 500	2.65	18 600	2.98	23 600	3.71	19 500	2.80	15 200	2.19
MLZ076	19 100	2.67	21 500	2.99	27 200	3.71	22 100	2.75	17 300	2.18	
R134a	MLZ015										
	MLZ019	2 800	2.40	3 200	2.75	4 300	3.60	3 600	2.73	2 600	2.05
	MLZ021	3 000	2.46	3 400	2.82	4 600	3.69	3 800	2.80	2 800	2.11
	MLZ026	3 700	2.49	4 200	2.87	5 600	3.75	4 700	2.84	3 400	2.13
	MLZ030	4 400	2.53	5 100	2.91	6 800	3.81	5 700	2.88	4 200	2.16
	MLZ038	5 200	2.45	6 000	2.80	8 000	3.66	6 700	2.78	4 900	2.09
	MLZ045	6 400	2.64	7 500	3.04	9 900	4.00	8 300	3.01	6 000	2.24
	MLZ048	6 800	2.60	7 900	2.99	10 500	3.90	8 800	2.95	6 400	2.21
	MLZ058	8 200	2.50	9 400	2.85	12 400	3.67	10 400	2.80	7 700	2.12
	MLZ066	9 500	2.55	11 000	2.91	14 500	3.76	12 100	2.86	8 900	2.17
MLZ076	10 500	2.50	12 200	2.86	16 100	3.68	13 500	2.81	9 900	2.13	
R22	MLZ/MLM015										
	MLZ/MLM019	4 500	2.64	5 100	3.01	6 500	3.81	5 500	2.93	4 200	2.25
	MLZ/MLM021	4 800	2.56	5 400	2.94	6 900	3.73	5 900	2.88	4 500	2.16
	MLZ/MLM026	6 000	2.85	6 900	3.25	8 800	4.09	7 500	3.12	5 700	2.39
	MLZ/MLM030	7 100	2.58	8 100	3.05	10 300	3.91	8 800	3.01	6 700	2.19
	MLZ/MLM038	8 300	2.59	9 400	3.02	12 100	3.86	10 300	2.97	7 800	2.20
	MLZ/MLM045	10 500	2.91	11 800	3.19	15 000	3.99	12 700	3.05	9 900	2.47
	MLZ/MLM048	11 100	2.82	12 700	3.16	16 400	3.99	13 900	3.06	10 600	2.39
	MLZ/MLM058	12 800	2.72	14 800	3.14	19 300	4.07	16 300	3.09	12 000	2.26
	MLZ/MLM066	15 100	2.83	17 300	3.25	22 400	4.12	19 000	3.20	14 400	2.43
MLZ/MLM076	17 600	2.96	20 000	3.31	25 600	4.15	21 800	3.20	16 600	2.48	

COP = Coefficient Of Performance

All performance data are for motor voltage code 4, 400V/3ph/50 Hz

* R507 performance data are nearly identical to R404A performance data

Capacity data at other conditions are available in the datasheets at: www.danfoss.com/odsg

60 Hz

Models	T _o =-10°C, T _c =40°C RGT=20°C, SC=0K Coldroom		T _o =-6.7°C, T _c =40°C RGT=20°C, SC=0K Ice machine		T _o =0°C, T _c =40°C RGT=20°C, SC=0K Air drier		T _o =-3°C, T _c =45°C RGT=20°C, SC=0K Milk tank		T _o =-10°C, T _c =45°C RGT=20°C, SC=0K EN12900 conditions		
	Capacity	COP	Capacity	COP	Capacity	COP	Capacity	COP	Capacity	COP	
	W	W/W	W	W/W	W	W/W	W	W/W	W	W/W	
R404A *	MLZ015										
	MLZ019	5 900	2.57	6 700	2.91	8 400	3.70	7 000	2.73	5 500	2.12
	MLZ021	6 300	2.58	7 100	2.92	9 000	3.70	7 500	2.76	5 800	2.13
	MLZ026	7 900	2.55	8 900	2.88	11 200	3.64	9 300	2.71	7 200	2.10
	MLZ030	9 300	2.64	10 400	2.97	13 200	3.73	11 000	2.79	8 500	2.18
	MLZ038	11 100	2.63	12 500	2.95	15 800	3.71	13 100	2.77	10 200	2.18
	MLZ045	13 400	2.67	15 200	3.01	19 100	3.79	15 900	2.82	12 400	2.19
	MLZ048	14 700	2.66	16 600	2.99	21 000	3.76	17 400	2.81	13 500	2.20
	MLZ058	17 400	2.62	19 800	2.95	25 200	3.68	20 500	2.75	15 700	2.14
	MLZ066	19 900	2.61	22 500	2.91	28 500	3.59	23 600	2.75	18 400	2.19
MLZ076	22 800	2.62	25 700	2.93	32 500	3.61	26 800	2.75	20 900	2.18	
R134a	MLZ015										
	MLZ019	3 400	2.46	4 000	2.82	5 400	3.68	4 500	2.82	3 200	2.11
	MLZ021	3 700	2.53	4 300	2.91	5 700	3.79	4 800	2.90	3 400	2.17
	MLZ026	4 500	2.59	5 300	2.97	7 000	3.86	5 900	2.96	4 200	2.22
	MLZ030	5 400	2.54	6 300	2.93	8 500	3.83	7 100	2.93	5 100	2.18
	MLZ038	6 400	2.52	7 400	2.91	9 900	3.80	8 300	2.90	6 000	2.16
	MLZ045	7 900	2.62	9 100	3.02	12 200	3.95	10 100	2.98	7 300	2.21
	MLZ048	8 300	2.61	9 700	2.99	12 900	3.88	10 700	2.94	7 800	2.21
	MLZ058	10 000	2.58	11 500	2.94	15 200	3.73	12 700	2.87	9 400	2.20
	MLZ066	11 500	2.61	13 200	2.95	17 400	3.74	14 600	2.88	10 800	2.22
MLZ076	12 900	2.54	14 900	2.89	19 600	3.67	16 400	2.82	12 100	2.16	
R22	MLZ/MLM015										
	MLZ/MLM019	5 400	2.40	6 300	2.77	8 100	3.55	6 900	2.76	5 200	2.09
	MLZ/MLM021	6 000	2.60	6 800	3.07	8 700	3.97	7 400	3.09	5 700	2.26
	MLZ/MLM026	7 600	2.86	8 500	3.20	10 700	3.95	9 200	3.07	7 300	2.41
	MLZ/MLM030	8 600	2.73	9 900	3.11	12 700	3.91	10 900	3.05	8 200	2.35
	MLZ/MLM038	10 300	2.82	11 700	3.13	15 000	3.89	12 800	3.04	9 800	2.41
	MLZ/MLM045	12 500	2.86	14 300	3.23	18 400	4.05	15 700	3.14	11 800	2.43
	MLZ/MLM048	13 700	2.84	15 700	3.21	20 100	4.05	17 100	3.13	12 900	2.41
	MLZ/MLM058	16 100	2.75	18 300	3.11	23 600	3.96	19 900	3.05	15 100	2.34
	MLZ/MLM066	18 500	2.79	21 000	3.15	27 000	3.97	23 000	3.10	17 500	2.41
MLZ/MLM076	21 700	2.80	24 600	3.18	31 300	4.01	26 700	3.12	20 600	2.40	

COP = Coefficient Of Performance

All performance data are for motor voltage code 4, 460V/3ph/60 Hz

* R507 performance data are nearly identical to R404A performance data

Capacity data at other conditions are available in the datasheets at: www.danfoss.com/odsg

MLZ/MLM015-019-021-026

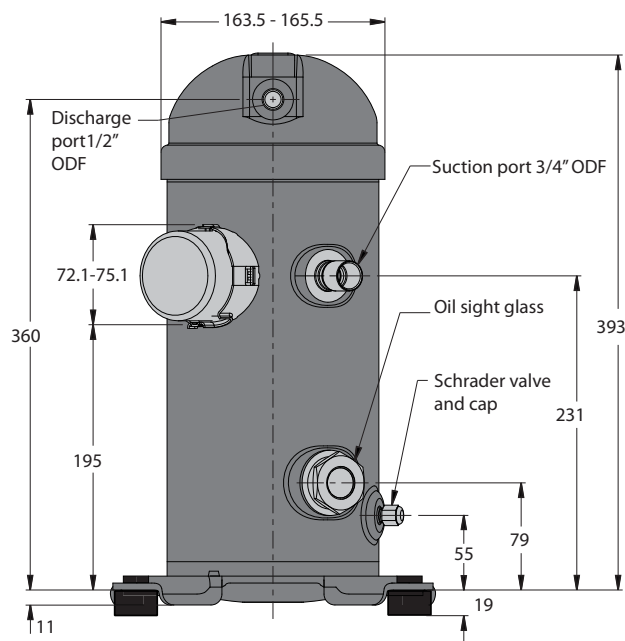
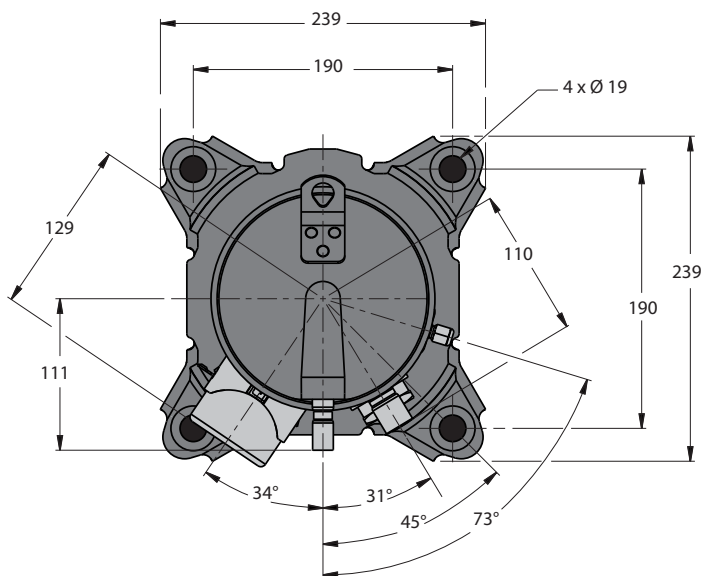

All dimensions in mm

Terminal box

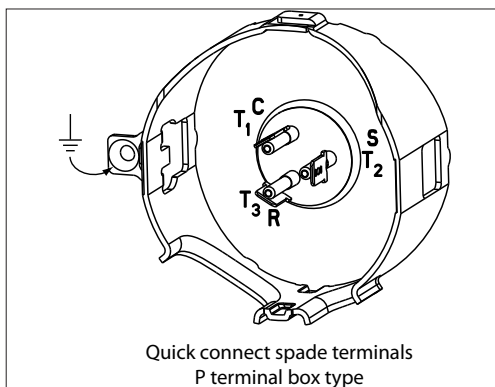

Mounting grommet

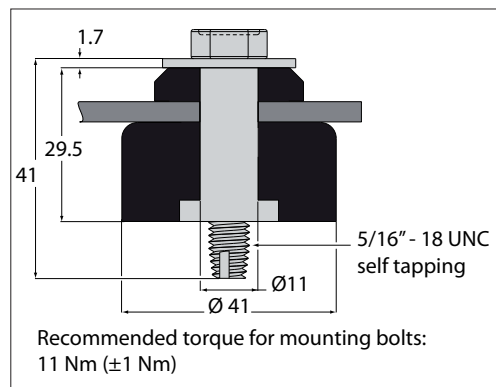

Refer to page 36 for overview of shipped mounting accessories

MLZ/MLM030-038-045-048

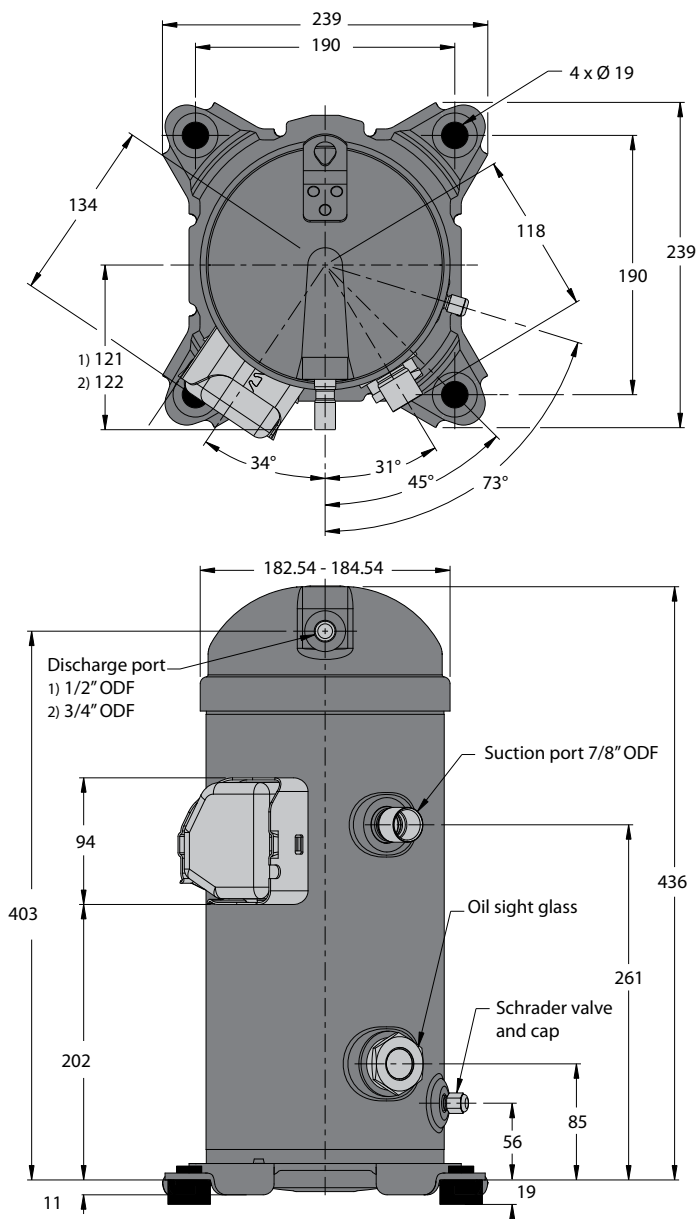

1) MLZ/MLM 030-038-045
2) MLZ/MLM 048

All dimensions in mm

Terminal box

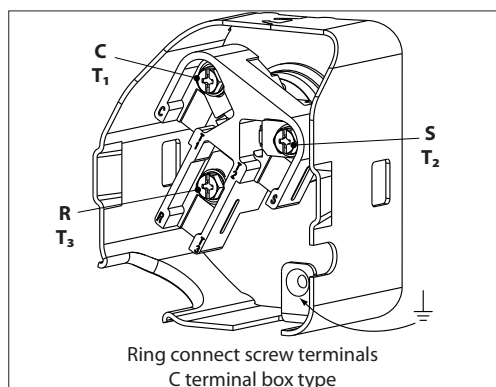

Ring connect screw terminals
C terminal box type

Mounting grommet

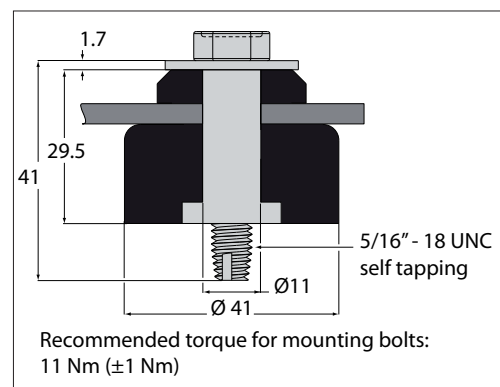

Refer to page 36 for overview of shipped mounting accessories

MLZ/MLM058-066-076

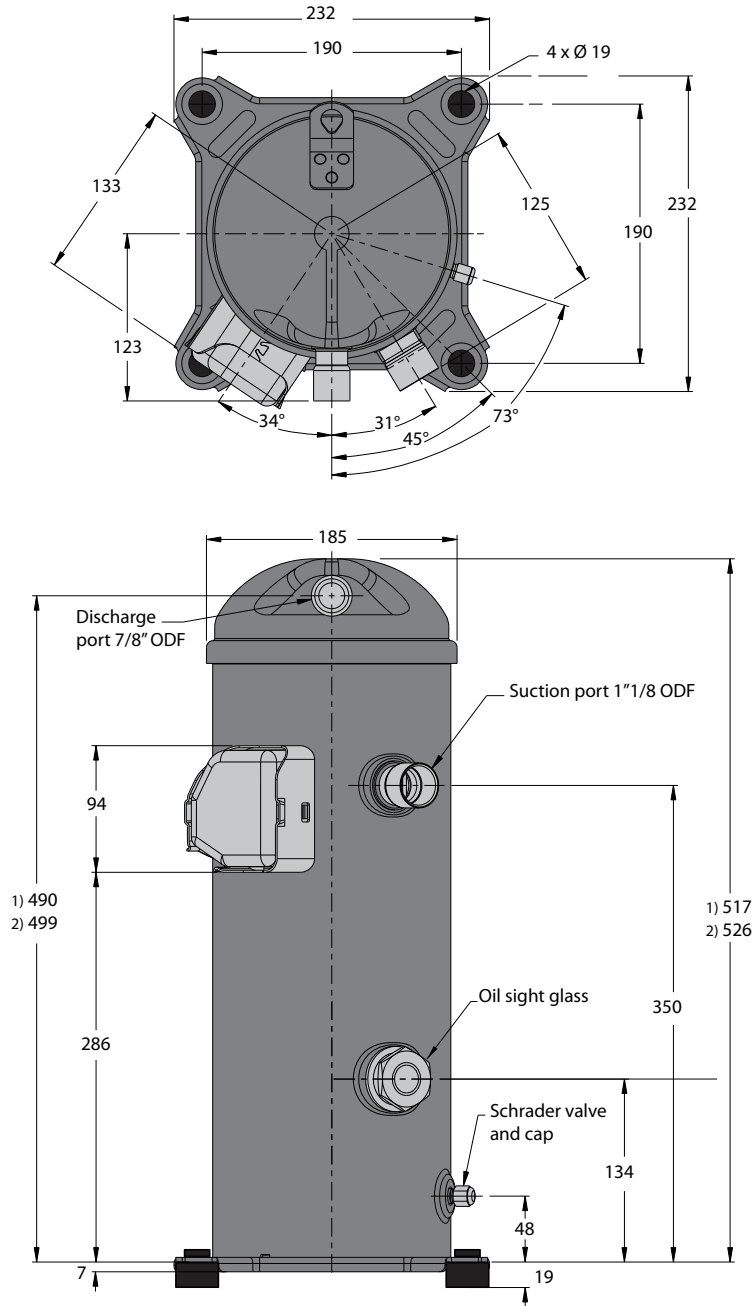

Terminal box

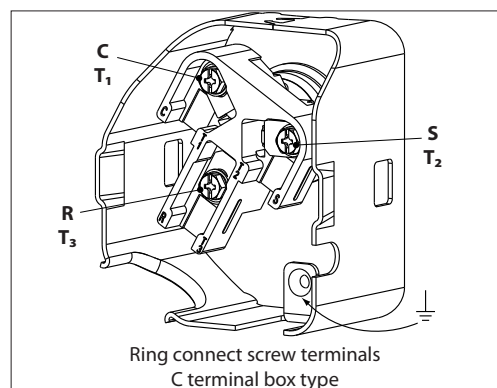

Mounting grommet

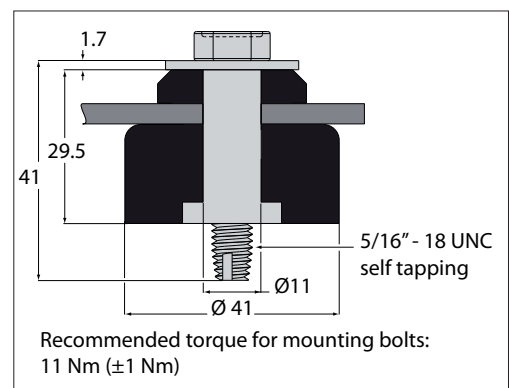

Refer to page 36 for overview of shipped mounting accessories

APPLICATION GUIDELINES
DIMENSIONS
Oil sight glass

MLZ / MLM scroll compressors come equipped with a threaded oil sight glass with 1 1/8" - 18 UNF connection. It can be used for a visual check of the oil amount and condition or it may be replaced by an accessory oil management device. The oil level must be visible in the sight glass during operation.

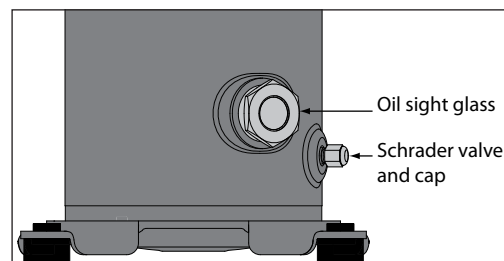

Schrader

The oil fill and drain connection and gauge port is a 1/4" male flare connector incorporating a schrader valve.

Suction and discharge connections

MLZ / MLM scroll compressors are factory delivered with brazed connections only. Dedicated

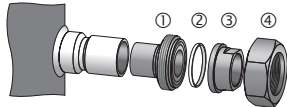
rotolock adaptors and adaptor sets are available as accessory.

Compressor models	Brazed connection size		 Rotalock adaptor set (① adaptor, ② gasket, ③ sleeve, ④ nut)			 Rotalock adaptor (① adaptor only)	
			Rotolock	Solder sleeve ODF	Code Number	Code Number	
MLZ/MLM 015-019-021-026	Suction	3/4"	1-1/4"	3/4"	120Z0126	120Z0366	
	Discharge	1/2"	1"	1/2"		120Z0365	
MLZ/MLM 030-038-045	Suction	7/8"	1-1/4"	7/8"	120Z0127	120Z0367	
	Discharge	1/2"	1"	1/2"		120Z0365	
MLZ/MLM 048	Suction	7/8"	1-1/4"	7/8"	120Z0128	120Z0367	
	Discharge	3/4"	1-1/4"	3/4"		120Z0366	
MLZ/MLM 058-066-076	Suction	1-1/8"	1-3/4"	1-1/8"	120Z0129	120Z0364	
	Discharge	7/8"	1-1/4"	7/8"		120Z0367	

Motor voltage

MLZ/MLM scroll compressors are available in 3 different motor voltages.

		Motor voltage code 1	Motor voltage code 2	Motor voltage code 4	Motor voltage code 5
50 Hz	Nominal voltage	-	200-220 V / 3 ph / 50 Hz	380-400 V / 3 ph / 50 Hz	220-240 V / 1 ph / 50Hz
	Voltage range	-	180 - 242 V	340 - 460 V	198 - 264 V
60 Hz	Nominal voltage	208-230 V / 1 ph / 60 Hz	208-230 V / 3 ph / 60 Hz	460 V / 3 ph / 60 Hz	-
	Voltage range	187 - 253 V	187 - 253 V	414 - 506 V	-

Wiring connections

MLZ/MLM scroll compressors will only compress gas while rotating counter-clockwise (when viewed from the compressor top). Since single-phase motors will start and run in only one direction, reverse rotation is not a major consideration. Three-phase motors, however, will start and run in either direction, depending on the phase angles of the supplied power. Care must be taken during installation to ensure that the compressor oper-

ates in the correct direction (see "Phase sequence and reverse rotation protection" page 18).

The drawings below show electrical terminal labelling and should be used as a reference when wiring the compressor. For three phase applications, the terminals are labelled T1, T2, and T3. For single-phase applications the terminals are labelled C (common), S (start), and R (run).

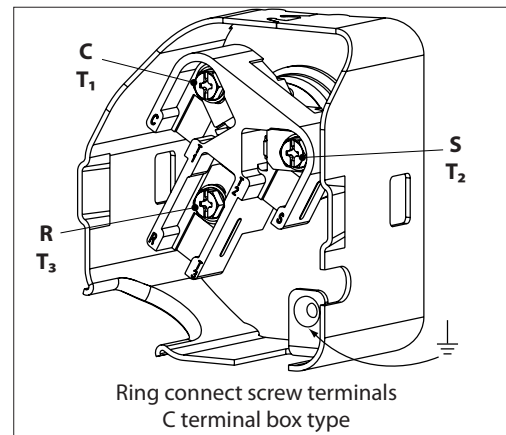
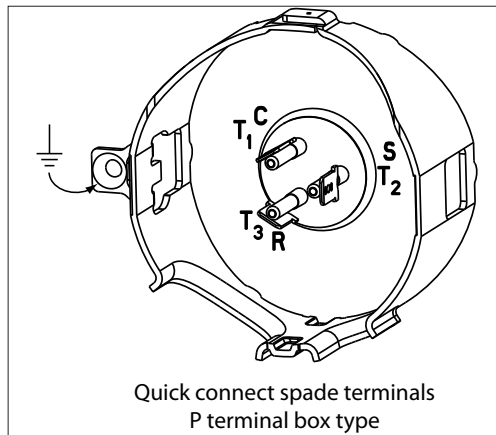

Terminal cover mounting

The terminal cover and gasket should be installed prior to operation of the compressor. Respect the "up" marking on gasket and cover and ensure that

the two outside tabs of the cover engage the terminal box.

Terminal cover removal

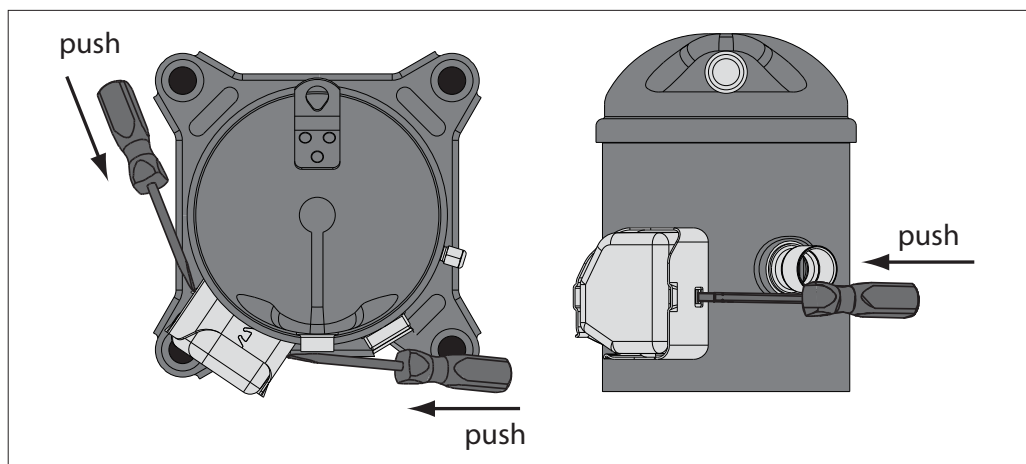

IP rating

The compressor terminal box IP rating according to CEI 529 is **IP22** for all models.

- First numeral, level of protection against contact and foreign objects
2 protection against object size over 12.5 mm (fingers of similar)
- Second numeral, level of protection against water
2 protection against dripping water when tilted up to 15°

Three phase electrical characteristics

Compressor model		LRA	MCC	Max Oper.A	Winding resistance (Ω)		
		A	A	A	T1-T3	T1-T2	T2-T3
Motor voltage code 4 380-400 V / 3 ph / 50 Hz, 460 V / 3 ph / 60 Hz	MLZ/MLM015T4						
	MLZ/MLM019T4	45	9.5	6.7	3.4	4.7	4.7
	MLZ/MLM021T4	45	9.5	6.8	3.4	4.7	4.7
	MLZ/MLM026T4	45	11	8.3	3.4	4.7	4.7
	MLZ/MLM030T4	60	13	9.8	2.6	2.6	2.6
	MLZ/MLM038T4	70	15	11.7	2.3	2.3	2.4
	MLZ/MLM045T4	82	15	14.1	1.9	1.9	1.8
	MLZ/MLM048T4	87	16	15.3	1.7	1.7	1.7
	MLZ/MLM058T4	95	20	18.1	1.4	1.4	1.4
	MLZ/MLM066T4	110	24	20.3	1.3	1.3	1.3
MLZ/MLM076T4	140	25	23.9	1.1	1.1	1.1	
Motor voltage code 2 200-220 V / 3 ph / 50 Hz 208-230 V / 3 ph / 60 Hz	MLZ019T2	95	17.5	13.3	0.87	1.18	1.18
	MLZ021T2	95	17.5	13.6	0.87	1.18	1.18
	MLZ026T2	95	22.0	16.6	0.87	1.18	1.18
	MLZ030T2	120	26.0	19.7	0.67	0.67	0.68
	MLZ038T2	123	26.0	23.5	0.60	0.60	0.61
	MLZ045T2	170	30.0	28.2	0.48	0.46	0.48
	MLZ048T2	190	37.0	30.6	0.43	0.44	0.43
	MLZ058T2	190	40.0	36.1	0.37	0.37	0.37
	MLZ066T2	235	46.0	40.7	0.32	0.32	0.33
	MLZ076T2	235	50.0	47.6	0.32	0.32	0.33

Single phase electrical characteristics

Compressor model		LRA	MCC	Max. Oper. A	Winding resistance (Ω)	
		A	A	A	run	start
Motor code 5 220-240 V / 1 ph / 50 Hz	MLZ/MLM 015T5					
	MLZ/MLM 019T5	97	23.0	18.3	0.69	1.51
	MLZ/MLM 021T5	97	25.0	19.5	0.69	1.51
	MLZ/MLM 026T5	97	27.0	24.2	0.69	1.51
	MLZ/MLM 030T5	127	32.0	28.9	0.42	1.31
	MLZ/MLM 038T5	130	42.0	33.9	0.39	1.02
Motor code 1 208-230 V / 1 ph / 60 Hz	MLZ019T1	97	25.0	19.9	0.67	1.57
	MLZ021T1	97	24.5	21.4	0.67	1.57
	MLZ026T1	115	31.5	26.8	0.55	1.47
	MLZ030T1	150	38.0	31.9	0.34	0.90
	MLZ038T1	160	45.0	37.2	0.28	1.76

LRA (Locked Rotor Amp)

LRA is the higher average current as measured on a mechanically blocked compressor tested under nominal voltage. LRA is printed on the nameplate.

The LRA value can be used as a rough estimation for the starting current. However in most cases, the real starting current will be lower. Many countries have defined limits for the starting current in domestic use. A soft starter can be applied to reduce starting current.

MCC (Maximum Continuous Current)

The MCC is the current at which the internal motor protection trips under maximum load and low voltage conditions.

This MCC value is the maximum at which the compressor can be operated in transient conditions and out of the application envelope. Above this value the overload will switch off to protect the motor.

Max Oper. A (Maximum Operating Amp)

The Max Oper. A is the current when the compressor operates at maximum load conditions and 10% below nominal voltage.

Max Oper. A can be used to select cables and contactors.

This value which is the max rated load current for the compressor is new on the nameplate.

In normal operation, the compressor current consumption is always less than the Max Oper. A value.

Winding resistance

Winding resistance is the resistance between indicated terminal pins at 25°C (resistance value +/- 7%).

Winding resistance is generally low and it requires adapted tools for precise measurement. Use a digital ohm-meter, a '4 wires' method and measure under stabilised ambient temperature. Winding resistance varies strongly with winding temperature ; If the compressor is stabilised at a different value than 25°C, the measured resistance must be corrected with following formula:

$$R_{t_{amb}} = R_{25^{\circ}C} \frac{a + t_{amb}}{a + t_{25^{\circ}C}}$$

- $t_{25^{\circ}C}$: reference temperature = 25°C
- t_{amb} : temperature during measurement (°C)
- $R_{25^{\circ}C}$: winding resistance at 25°C
- R_{amb} : winding resistance at t_{amb}
- coefficient $a = 234.5$

Electrical connections

MLZ / MLM single phase scroll compressors are designed to operate without any assistance. If

starting within the defined voltage range, PSC wiring is sufficient.

PSC wiring

PSC wiring with a run capacitor only is the default wiring solution for single phase MLZ and MLM compressors.

The start winding (C-S) of the motor remains in circuit through a permanent (run) capacitor. This permanent (run) capacitor is connected between the start winding (S) and the run winding (R).

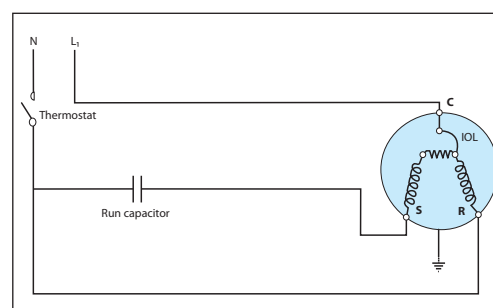

PTCSCR wiring

If the starting torque of the PSC wiring is not sufficient due to pressures not fully equalized during the off-cycle or some voltage drop during starting, the PTCSCR wiring might be an option. PTCSCR wiring provides more motor torque than PSC wiring but less than CSR wiring. The PTC is wired in parallel to the run capacitor.

When starting the compressor, the PTC, which is at low resistance, provides additional starting current to the motor's start winding. The current passing through the PTC causes it to heat up and, at a certain temperature, change to a very high resistance. At this time the motor is up to nominal speed and the run capacitor determines the current through the start winding. The PTC remains at high temperature and thus at high resistance as long as power is connected to the compressor. When the compressor is switched off, the PTC cools down to its initial low resistance and becomes available to support the next compressor start.

It is important to provide sufficient time between motor starts to allow the PTC to cool down close to ambient temperature. Depending on the ambient conditions and the cooling of the PTC, this may take about 5 minutes. A restart before the PTC is back to low resistance may be successful or the motor may stall in a locked-rotor state depending on the ambient and system's conditions. A locked-rotor state causes the internal protector to open and would cause even further delay until the overload is reset.

The following PTC types are recommended for the MLZ/MLM single phase compressors:

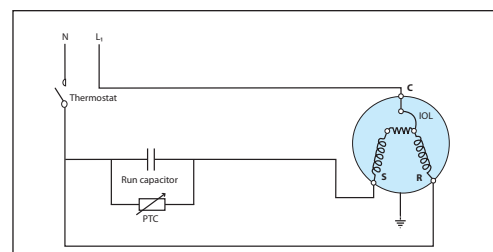

Model	Voltage code 1 208-230 V/1~/60 Hz	Voltage code 5 220-240 V/1~/50 Hz
MLZ/MLM015	305C12*	305C9* / 305C11*
MLZ/MLM019	305C9* / 305C11*	305C9* / 305C11*
MLZ/MLM021	305C9* / 305C11*	305C9* / 305C11*
MLZ/MLM026	305C12*	305C9* / 305C11*
MLZ/MLM030	305C9* / 305C11*	305C9* / 305C11*
MLZ/MLM038	305C9* / 305C11*	305C9* / 305C11*

Note: MLZ compressors with PTCSCR are not approved by UL. It is the customers' responsibility to get final approval for the system when required.

CSR wiring

CSR wiring provides additional motor torque at start-up, by the use of a start capacitor in combination with the run capacitor. The start capacitor is only connected during the starting operation, a potential relay is used to disconnect it after the start sequence.

Some applications with high differential pressure and start duty as "soft serve ice cream machine" can require CSR wiring. This configuration can also be used to reduce erratic starting at unfavourable conditions such as very low ambient temperature or weak voltage.

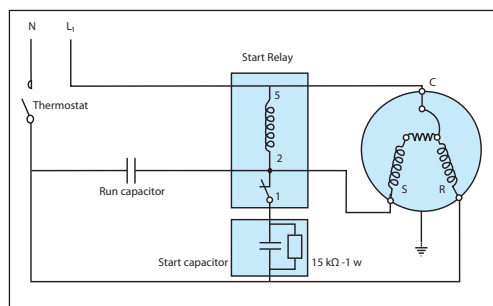

Nominal capacitor value and relays

	Compressor models	Default solution: PSC wiring with run capacitor only					
		PSC wiring		Additional components for CSR wiring			
		Run capacitor		Start capacitor		Relay	
		μF	Volt	μF	Volt	Reference	
220-240 V / 1/50 Hz Motor voltage code 5	MLZ/MLM015-019-021-026	70	370	145-175	330	3ARR3J3AL4	RVA9CKL
	MLZ/MLM030	50	370	161-193	250	3ARR3J24AP4	RVA3EKL
	MLZ/MLM038-045-048	55	440	88-108	330	3ARR3J25AS4	RVA4GKL
208-230 V / 1 / 60 Hz Motor voltage code 1	MLZ/MLM019-021	45	370	145-175	250	3AAR3*3M*	
	MLZ/MLM026	60	370	88-108	330	3ARR3*3L*	
	MLZ/MLM030-033	60	370	161-193	250	3ARR3*3L*	
	MLZ/MLM038	55	440	88-108	250	3ARR3*25S*	

Three phase

Suggested wiring diagram with "one shot" pump down cycle and safety lock-out relay

- Control device TH
- Optional short cycle timer (3 min) 180 s
- Control relay KA
- Liquid Line Solenoid valve LLSV
- Compressor contactor KM
- Phase monitor PM
- Safety lock out relay KS
- Pump-down control low pressure switch . LP
- High pressure safety switch HPs
- Fused disconnect Q1
- Fuses F1
- Compressor motor M
- Discharge gas thermostat DGT

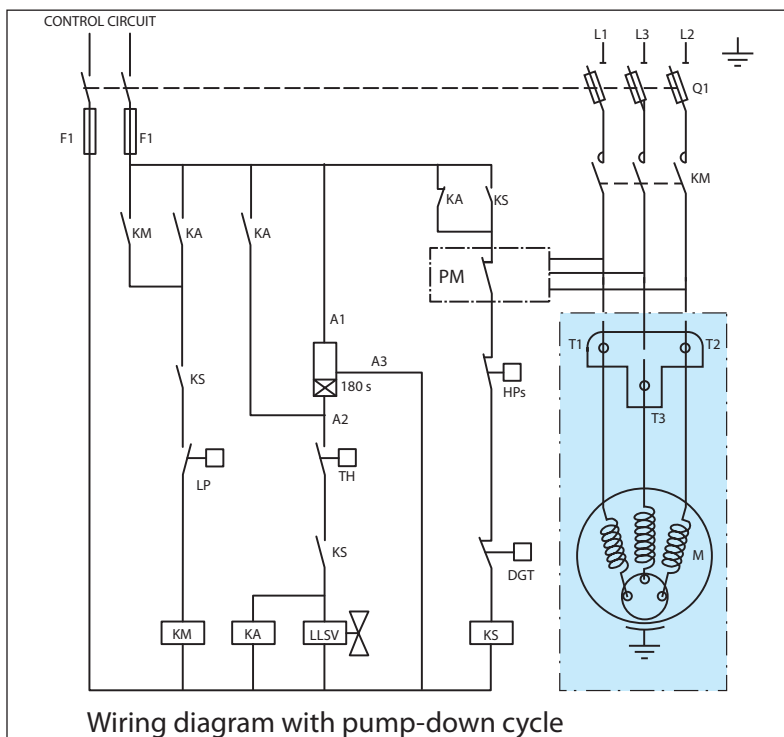

Wiring diagram with pump-down cycle

Internal motor protection

MLZ/MLM scroll compressors are equipped with an internal line break protector mounted on the motor windings. The protector is an automatic reset device, containing a snap action bimetal switch.

Internal protectors respond to over-current and overheating. They are designed to interrupt mo-

tor current under a variety of fault conditions, such as failure to start, running overload, and fan failure.

If the internal overload protector trips out, it must cool down to about 60°C to reset. Depending on ambient temperature, this may take up to several hours.

Phase sequence and reverse rotation protection

The compressor will only operate properly in a single direction. Use a phase meter to establish the phase orders and connect line phases L1, L2 and L3 to terminals T1, T2 and T3, respectively. For three-phase compressors, the motor will run equally well in both directions. Reverse rotation results in excessive noise; no pressure differential between suction and discharge; and suction line warming rather than immediate cooling. A service technician should be present at initial start-up to verify that supply power is properly phased and that compressor and auxiliaries are rotating in the correct direction.

MLZ/MLM015-038 scroll compressors are designed to operate for a maximum of 150 hours in reverse, but as a reverse rotation situation can go unnoticed for longer periods, phase monitors are recommended.

For compressors MLZ/MLM048 and larger, phase monitors are required. The selected phase monitor should lock out the compressor from operation in reverse.

At brief power interruptions, reverse rotation can occur with single phase compressors. In this case the internal protector will stop the compressor. It will have to cool down and will restart safely afterwards.

Voltage imbalance

For three-phase applications the voltage measured at the compressor terminals for each phase

should be within $\pm 2\%$ of the average for all phases.

Approvals and certificates MLZ scroll compressors comply with the following approvals and certificates. Certificates are listed on the product datasheets: <http://www.danfoss.com/odsg>

CE 0062 or CE 0038 (European Directive)		All MLZ models
UL (Underwriters Laboratories)		Models with motor code 1, 2 & 4 except when using PTSCSR system
Other approvals / certificates		Contact Danfoss

Conformity to directives

Pressure equipment directive 97/23/EC
Machinery directive 98/35/EC annex II b

Low voltage directive 2006 / 95 EC
Electromagnetic compatibility 2004/108/CE

Products	MLZ / MLM 015 to 076
Refrigerating fluids	Group 2
Category PED	I
Evaluation module	no scope
Service temperature - Ts	-35°C < Ts < 55°C
MLZ - Service pressure - Ps	25.44 bar(g)
MLM - Service pressure - Ps	20.74 bar(g)
Declaration of conformity	contact Danfoss
Marking of conformity	CE

Internal free volume

Products	Internal free volume at LP side without oil (litre)
MLZ/MLM 015 - 026	1.85
MLZ/MLM 030-048	1.85
MLZ/MLM 058-076	6.15

The scroll compressor application range is influenced by several parameters which need to be monitored for a safe and reliable operation. These parameters and the main recommendations for good practice and safety devices are explained hereunder.

- **Refrigerant and lubricants**
- **Motor supply**
- **Compressor ambient temperature**
- **Application envelope** (evaporating temperature, condensing temperature, return gas temperature)

Refrigerant and lubricants

General information

When choosing a refrigerant, different aspects must be taken into consideration:

- Legislation (now and in the future)
- Safety
- Application envelope in relation to expected running conditions
- Compressor capacity and efficiency
- Compressor manufacturer recommendations & guidelines

Additional points could influence the final choice:

- Environmental considerations
- Standardisation of refrigerants and lubricants
- Refrigerant cost
- Refrigerant availability

R22 R22 is an HCFC refrigerant and is still a wide use today. It has a low ODP (Ozone Depletion Potential) and therefore it will be phased out in the future. Check local legislation.

When R22 is applied in refrigeration applications it can lead to high discharge temperature. Carefully check all other parameters that can influence the discharge temperature.

R134a Refrigerant R134a is an HFC refrigerant. R134a has zero ozone depletion potential (ODP = 0) and is commonly accepted as the best R12 alternative. R134a is a pure refrigerant and has zero tempera-

ture glide. For applications with high evaporating and high condensing temperatures, R134a is the ideal choice.

R404A R404A is an HFC refrigerant. R404A has zero ozone depletion potential (ODP = 0). R404A is especially suitable for low evaporating temperature applications but it can also be applied to medium evaporating temperature applications. R404A is a

mixture and has a very small temperature glide, and therefore must be charged in its liquid phase, but for most other aspects this small glide can be neglected. Because of the small glide, R404A is often called a near-azeotropic mixture.

R507 R507 is an HFC refrigerant with properties comparable to R404A. R507 has no ozone depletion potential (ODP = 0). As with R404A, R507 is particularly suitable for low evaporating temperature

applications but it can also be used for medium evaporating temperature applications. R507 is an azeotropic mixture with no temperature glide.

PVE Polyvinyl ether (PVE) is an innovative refrigeration lubricant for HFC refrigerant systems. PVE is as hygroscopic as existing polyolester lubricants (POE), but PVE doesn't chemically react with water; no acids are formed and compressor evacuation is easier.

The compressor technology applied in MLZ compressors in combination with PVE lubricant provides the best possible result in terms of reliability and compressor lifetime. The PVE lubricant is compatible with R22 which makes the MLZ compressors a very versatile multi-refrigerant solution.

Alkylbenzene oil Alkylbenzene oil can be applied in systems using HCFC refrigerants (R22). Compared to a mineral oil it provides distinct advantages: excellent miscibility, excellent thermal stability, compatibility with mineral oils and constant quality.

MLM series compressors are charged with Alkylbenzene oil and herewith offer an economically interesting alternative to the MLZ series in regions where R22 is still the predominant refrigerant. Note however that MLM compressors can not be used with HFC refrigerants.

Motor supply

MLZ / MLM scroll compressors can be operated at nominal voltages as indicated on page 14. Under-voltage and over-voltage operation is allowed within the indicated voltage ranges. In case of

risk of under-voltage operation, special attention must be paid to current draw and start assist for single-phase compressors may be required.

Compressor ambient temperature

MLZ / MLM compressors can be applied from -35°C to 50°C ambient temperature. The compressors are designed as 100 % suction gas cooled

without need for additional fan cooling. Ambient temperature has very little effect on the compressor performance.

High ambient temperature

In case of enclosed fitting and high ambient temperature it's recommend to check the temperature of power wires and conformity to their insulation specification.

In case of safe tripping by the internal compressor overload protection the compressor must cool down to about 60°C before the overload will reset. A high ambient temperature can strongly delay this cool-down process.

Low ambient temperature

Although the compressor itself can withstand low ambient temperature, the system may require specific design features to ensure safe and reli-

able operation. See section 'Specific application recommendations'.

Application envelope

The operating envelopes for MLZ/MLM scroll compressors are given in the figures below, where the condensing and evaporating temperatures represent the range for steady-state operation. Under transient conditions, such as start-up and defrost, the compressor may operate outside this envelope for short periods.

R134a and R22. The operating limits serve to define the envelope within which reliable operations of the compressor are guaranteed:

- Maximum discharge gas temperature: +135°C
- A suction superheat below 5 K is not recommended due to the risk of liquid flood back
- Minimum and maximum evaporating and condensing temperatures as per the operating envelopes.

The figures below show the operating envelopes for MLZ compressors with refrigerants R404A/507,

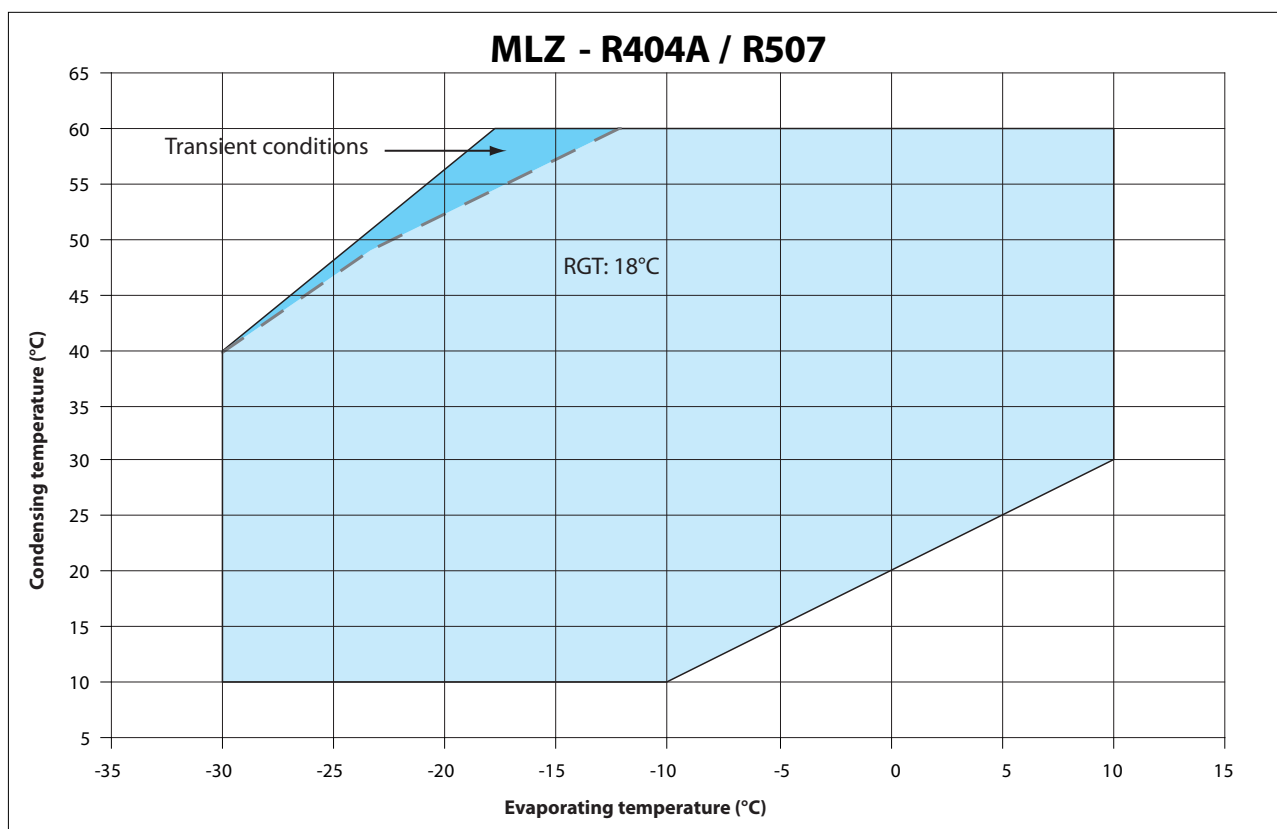

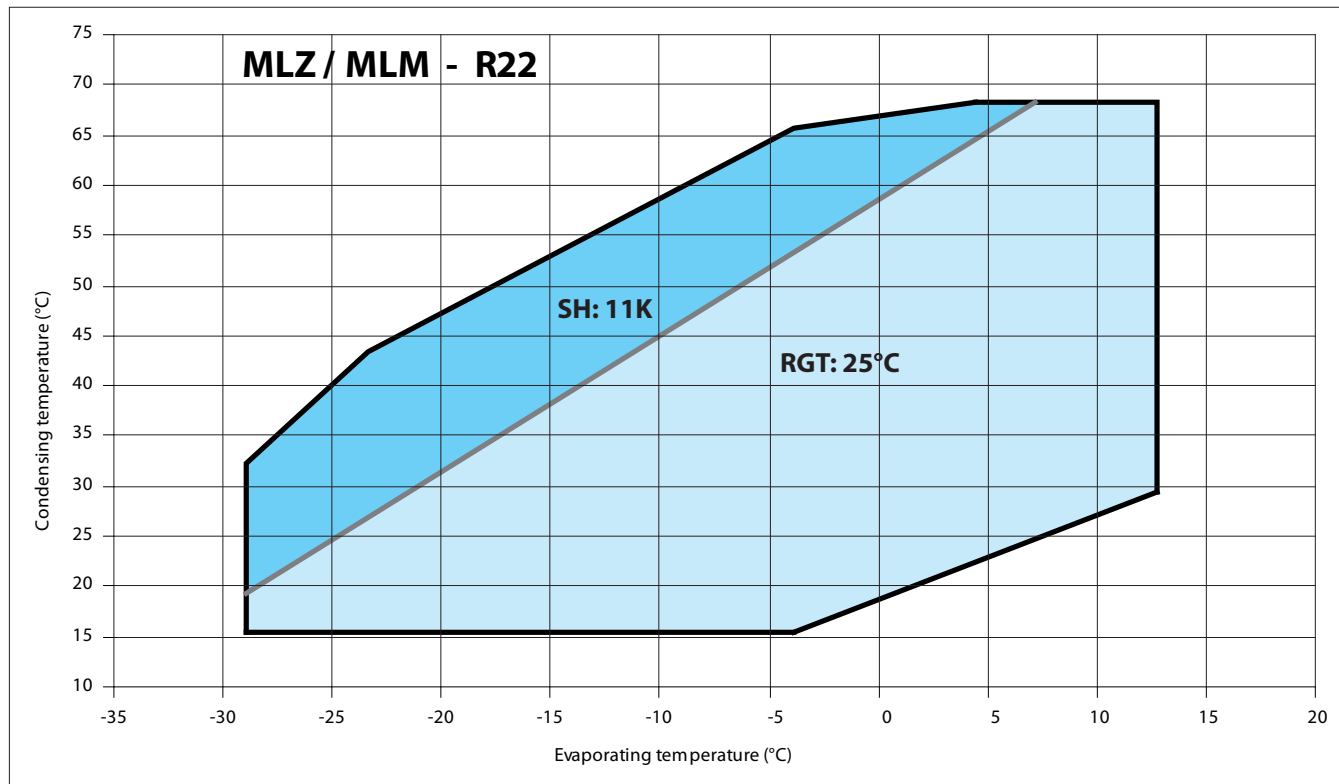
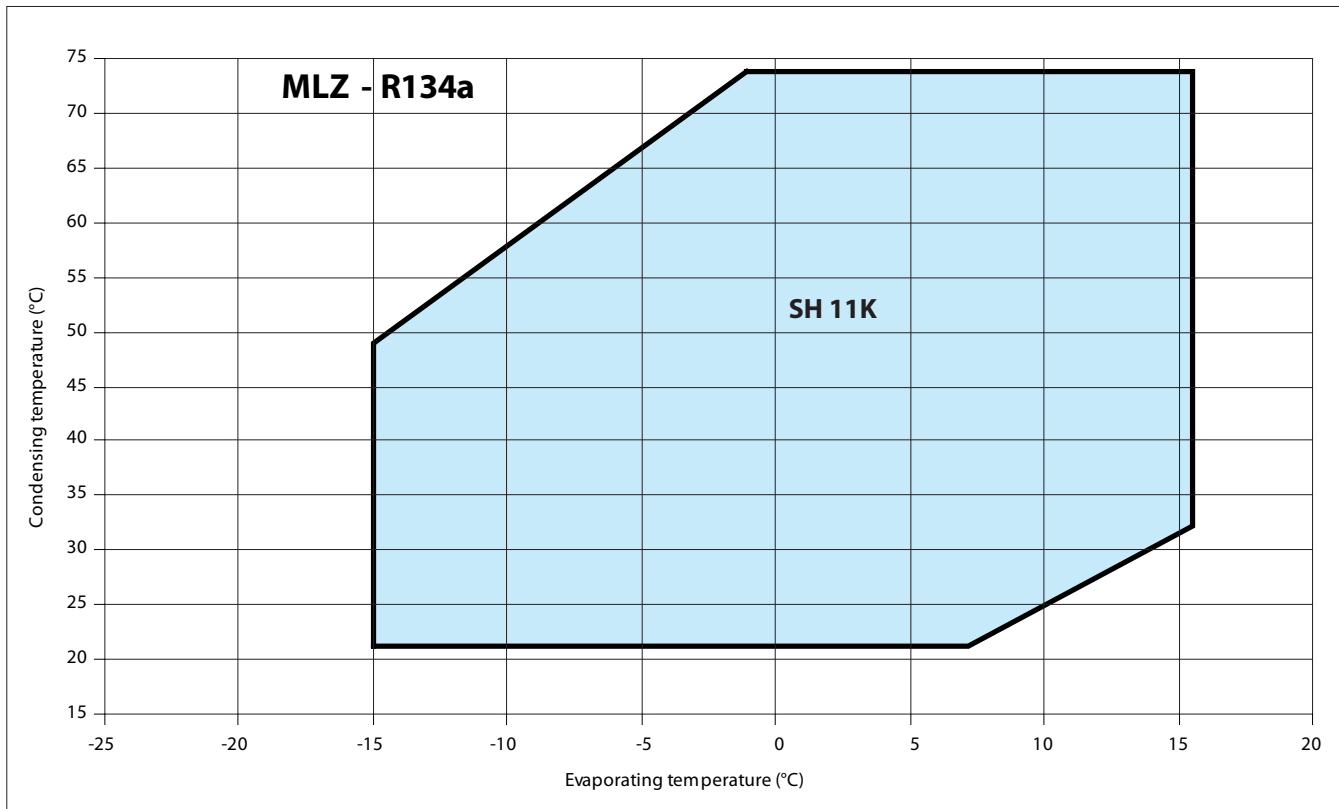

Maximum discharge gas temperature

The discharge temperature depends mainly on the combination of evaporating temperature, condensing temperature and suction gas superheat. Discharge gas temperature should be controlled with an isolated thermocouple or thermo-

stat attached to the discharge line 15 cm (6 inches) from the compressor shell. Maximum discharge gas temperature must not exceed 135°C (275°F) when the compressor is running within the approved operating envelope.

Discharge gas temperature protection (DGT)

DGT protection is required if the high and low pressure switch settings do not protect the compressor against operations beyond its specific application envelope. Please refer to the examples below, which illustrate where DGT protection is required (n°1) and where it is not (n°2).

The compressor must not be allowed to cycle on the discharge gas thermostat. Continuous operations beyond the compressor's operating range will cause serious damage to the compressor!

A DGT accessory is available from Danfoss: refer to page 39.

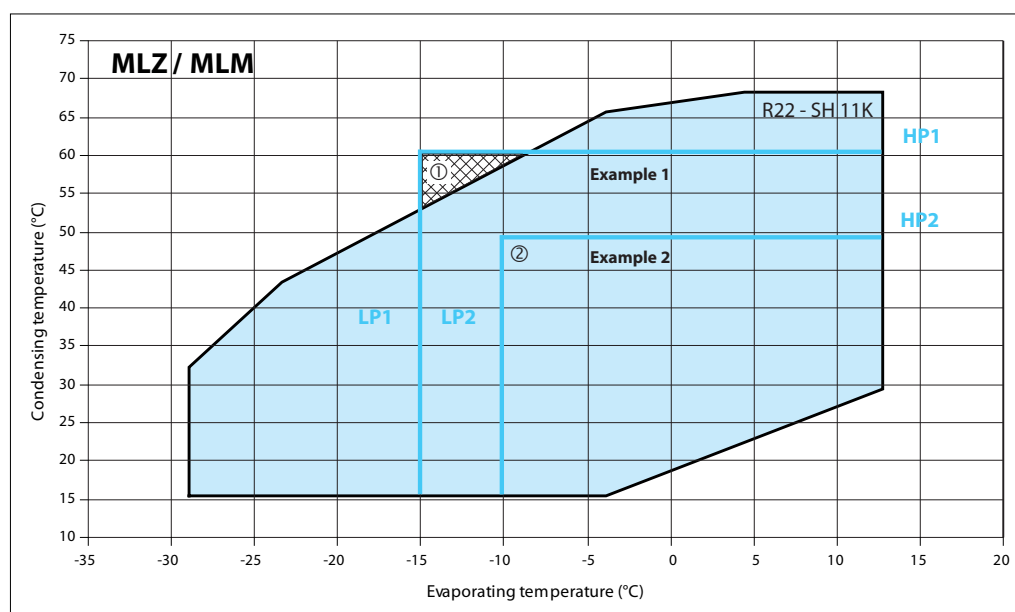

Example 1 (R22, SH = 11 K)
 LP switch setting: LP1 = 2 bar (g) (-15°C)
 HP switch setting: HP1 = 23.8 bar (g) (61°C)
 ① The LP and HP switches don't protect sufficiently from operation outside the envelope. A DGT protection is required to avoid operation in the hatched area.

Example 2 (R22, SH = 11 K)
 LP switch setting: LP2 = 2.5 bar (g) (-10°C)
 HP switch setting: HP2 = 17 bar (g) (49°C)
 ② The LP and HP switches protect from operation outside the envelope. No DGT protection required.

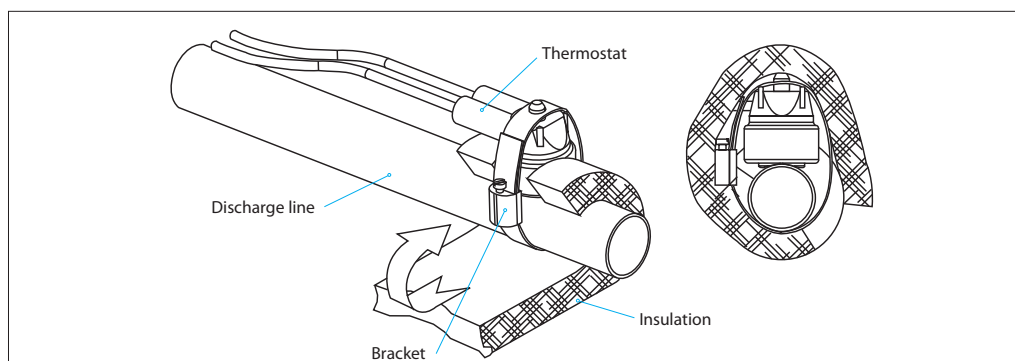

High and low pressure protection

		R22	R404A	R134a
Working pressure range high side	bar (g)	7.03 - 27.9	7.20 - 27.7	4.91 - 22.1
Working pressure range low side	bar (g)	0.71 - 6.4	1.04 - 7.2	0.64 - 4.0
Maximum high pressure safety switch setting	bar (g)	29.8	29.7	23.6
Minimum low pressure safety switch setting ①	bar (g)	0.51	0.80	0.45
Recommended pump-down switch settings		1.5 bar below nominal evaporating pressure		
Minimum low pressure pump-down switch setting	bar (g)	0.94	1.31	0.85

① LP safety switch shall never have time delay.

High pressure

MLZ/MLM 015-048 scroll compressors are equipped with an internal pressure relief valve (IPRV), for protection against blocked condenser and fan failure conditions (IPRV setting 32 bar +/- 4 differential pressure HP / LP). Still, a high pressure (HP) safety switch is recommended.

MLZ/MLM058-068-076 scroll compressors are not equipped with an internal pressure relief valve; therefore a high pressure switch is required to shut down the compressor should the discharge

pressure exceed the values shown in the table above.

The high-pressure switch can be set to lower values depending on the application and ambient conditions. The HP switch must either be placed in a lockout circuit or consist of a manual reset device to prevent cycling around the high-pressure limit. If a discharge valve is used, the HP switch must be connected to the service valve gauge port, which must not be isolated.

Low pressure

A low pressure (LP) safety switch is recommended. MLZ/MLM scroll compressors exhibit high volumetric efficiency and may draw very low vacuum levels, which could induce scroll instability and electrical arcing at the internal cluster. The minimum low-pressure safety switch setting is given in the above table. For systems without

pump-down, the LP safety switch must either be a manual lockout device or an automatic switch wired into an electrical lockout circuit. The LP switch tolerance must not allow for vacuum operations of the compressor. LP switch settings for pump-down cycles with automatic reset are also listed in the table above.

On/off cycling (cycle rate limit)

Depending on the application, a number higher than 12 starts per hour can reduce the service life of the motor-compressor unit. A one-minute time out is recommended.

The system must be designed in a way that provides a minimum compressor running time of 2 minutes so as to provide for sufficient motor cooling after start-up along with proper oil return.

Note that the oil return may vary since it depends upon system design.

Danfoss recommends a restart delay timer to limit compressor cycling.

General

Successful application of scroll compressors is dependent on careful selection of the compressor for the application. If the compressor is not

correct for the system, it will operate beyond the limits given in this manual. Poor performance, reduced reliability, or both may result.

Essential piping design considerations

Proper piping practices should be employed to ensure adequate oil return, even under minimum load conditions with special consideration given to the size and slope of the tubing coming from the evaporator. Tubing returns from the evaporator should be designed so as not to trap oil and to prevent oil and refrigerant migration back to the compressor during off-cycles.

If the evaporator lies above the compressor the addition of a pump-down cycle is strongly recommended. If a pump-down cycle were to be omitted, the suction line must have a loop at the evaporator outlet to prevent refrigerant from draining into the compressor during off-cycles.

If the evaporator were situated below the compressor, the suction riser must be trapped to ensure the oil return to the compressor (see fig.1).

When the condenser is mounted at a higher position than the compressor, a suitably sized «U»-shaped trap close to the compressor is necessary to prevent oil leaving the compressor from drain-

ing back to the discharge side of the compressor during off cycle. The upper loop also helps avoid condensed liquid refrigerant from draining back to the compressor when stopped (see fig. 2). The maximum elevation difference between the indoor and outdoor section cannot exceed 8 m. System manufacturers should specify precautions for any applications that exceed these limits to ensure compressor reliability.

Piping should be designed with adequate three-dimensional flexibility (figure 2). It should not be in contact with the surrounding structure, unless a proper tubing mount has been installed. This protection proves necessary to avoid excess vibration, which can ultimately result in connection or tube failure due to fatigue or wear from abrasion. Aside from tubing and connection damage, excess vibration may be transmitted to the surrounding structure and generate an unacceptable sound level within that structure as well (for more information on sound and vibration, see the section on: «Sound and vibration management» page 31).

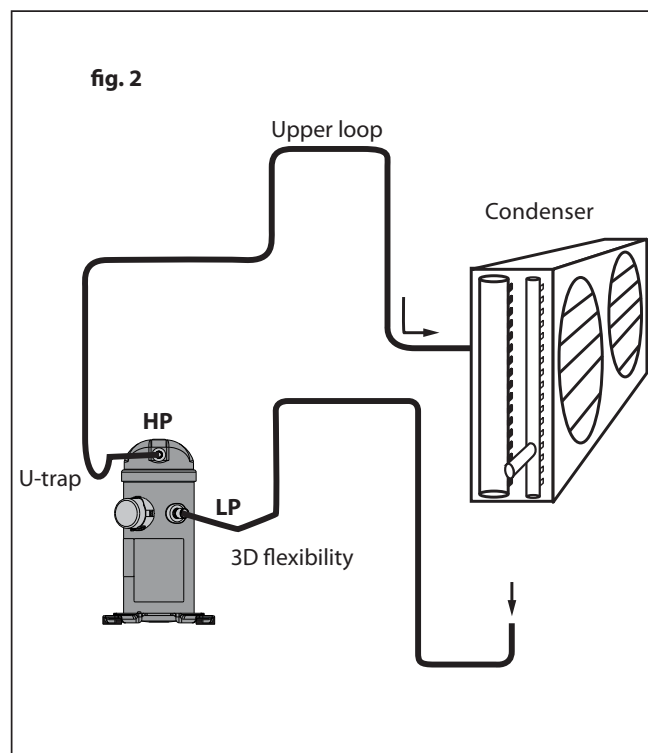
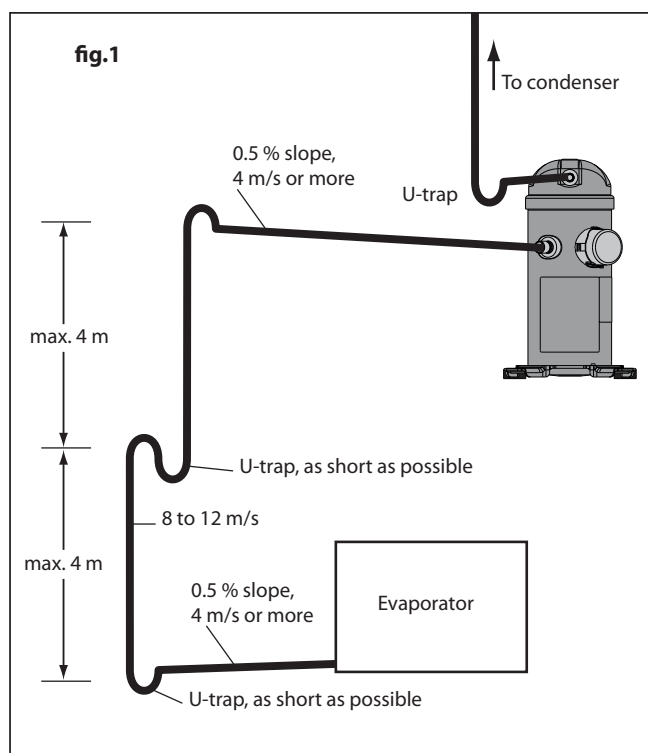

Refrigerant charge limit

MLZ/MLM scroll compressors can tolerate liquid refrigerant up to a certain extend without major problems. However, excessive liquid refrigerant in the compressor is always unfavourable for service life. Besides, the installation cooling capacity may be reduced because of the evaporation taking place in the compressor and/or the suction line instead of the evaporator. System design must be such that the amount of liquid refrigerant in the

compressor is limited. In this respect, follow the guidelines given in the section: "essential piping design recommendations" in priority. Use the tables below to quickly evaluate the required compressor protection in relation with the system charge and the application. More detailed information can be found in the paragraphs hereafter. Please contact Danfoss for any deviation from these guidelines.

Model	Refrigerant charge limit (kg)
MLZ015-026	3.6
MLZ030-048	5.4
MLZ058-076	7.2

Depending on test results, crankcase heaters, Liquid Line Solenoid Valve, pump down or suction accumulator must be applied see below.

	BELOW charge limit	ABOVE charge limit
Packaged units	<input checked="" type="checkbox"/> No test or additional safeties required	REQ Off cycle migration test REQ Liquid flood back test
System with remote heat exchanger	REC Off cycle migration test	REQ Off cycle migration test REQ Liquid flood back test

REC Recommended **REQ** Required No test or additional safeties required

Note: for special conditions such as low ambient temperature, low load operation or brazed plate heat exchangers please refer to corresponding sections

Off-cycle migration

Off-cycle refrigerant migration is likely to occur when the compressor is located at the coldest part of the installation, when the system uses a bleed-type expansion device, or if liquid could migrate from the evaporator into the compressor sump by gravity. If too much liquid refrigerant accumulates in the sump it will saturate the oil and lead to a flooded start: when the compressor starts, the refrigerant evaporates abruptly under the sudden

decrease of the bottom shell pressure, causing the oil to foam. In extreme situations, this might result in too much oil leaving the compressor, which must be avoided as it causes irreversible damages due to possible lack of lubrication.

MLZ/MLM scroll compressors can tolerate occasional flooded starts as long as the system has been evaluated.

A suitable test to evaluate the risk of off-cycle migration is the following:

- Stabilize the non running system at 5°C ambient temperature.
- Raise the ambient temperature to 20°C and keep it for 10 minutes.
- Start the compressor and monitor sump temperature, sight glass indication and sound level.

The presence of liquid in the crankcase can be easily detected by checking the sump level through the oil sight glass. Foam in the oil sump indicates a flooded start.

A noisy start, oil loss from the sump and sump cool down are indications for migration. Depending on the amount of migration graduate measures shall be taken:

- **Crankcase heater**
- **Liquid line solenoid valve**
- **Pump down cycle**

Crankcase heater: when the compressor is idle, the oil temperature in the sump must be maintained at no lower than 10 K above the saturation temperature of the refrigerant on the low-pressure side. This requirement ensures that the liquid refrigerant is not accumulating in the sump. A crankcase heater is only effective if capable of sustaining this level of temperature difference. Tests

must be conducted to ensure that the appropriate oil temperature is maintained under all ambient conditions (temperature and wind). Below -5°C ambient temperature and a wind speed of above 5m/sec, it's recommended to thermally insulated the heaters in order to limit the surrounding energy losses.

Due to the Danfoss scroll compressors inherent ability to handle liquid refrigerant, crankcase heaters are not required when the system charge does not exceed the recommended maximum charge.

Since the total system charge may be undefined, a crankcase heater is recommended on all systems with remote heat exchangers. In addition, any system containing a refrigerant charge in excess of the maximum recommended system charge for compressors requires a crankcase heater.

Belt-type crankcase heater accessories are available from Danfoss (see page 39).

The heater must be energized whenever the compressor is off.

Provide separate electrical supply for the heaters so that they remain energized even when the machine is out of service (eg. Seasonal shutdown).

It is recommended that the heater be turned on for a minimum of 12 hours prior to starting the compressor.

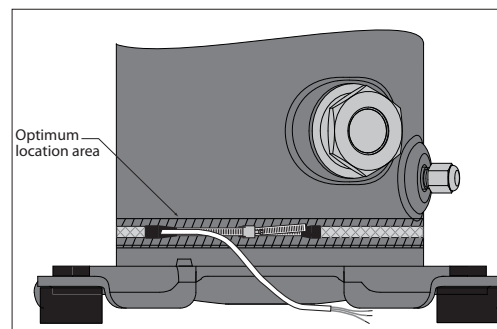

Liquid line solenoid valve (LLSV): This feature is very convenient and can be used on all types of applications.

An LLSV is used to isolate the liquid charge in the high pressure side, thereby preventing against

charge transfer or excessive migration to the compressor during off-cycles. The quantity of refrigerant remaining in the low-pressure side of the system can be further reduced by using a pump-down cycle in association with the LLSV.

Pump-down cycle: Once the system has reached its set point and is about to shut off, the LLSV on the liquid line closes. The compressor then pumps the majority of the refrigerant charge into the high pressure side before the system stops on the low pressure pump-down switch. This step reduces the amount of charge on the low side in order to prevent off-cycle migration.

A pump-down cycle represents one of the most effective ways to protect against the off-cycle migration of refrigerant; however it is only convenient to apply on application with thermostatic control.

Rack application with pressostatic control can use timer delay to empty the evaporators before the stop. Time should be carefully set to not interfere with the low safety pressure switch.

For low pressure pump-down switch settings, refer to page 24. For suggested wiring diagrams, please see page 17.

Models MLZ/MLM015-048 incorporate an internal low leak check valve that is appropriate for pump-down operations. This valve prevents the back flow of refrigerant from the high pressure to the low pressure side through the compressor so pump down conditions can be achieved and maintained.

Models MLZ/MLM058-076 are not equipped with this low leak check valve. Under certain conditions, the internal valve may not completely seal, and due to the refrigerant back flow the compressor might restart during pump-down applications. Repeated short cycling can result in a compressor breakdown. It is recommended to install an external magnetic check valve (such as Danfoss Part No. 120Z5046) close to the compressor's discharge connector so the discharge volume is minimized.

A magnetic check valve is recommended for this as it offers the best solution regarding minimal required and maximal pressure drop over the wide application envelope of the MLZ/MLM compressors. If a Danfoss NRV check valve is applied it has to be carefully selected for the specific operation conditions of the individual system.

Tests for pump down cycle approval:

- As the pump-down switch setting is inside the application envelope, tests should be carried out to check unexpected cut-out during transient conditions (ie. defrost – cold starting). When unwanted cut-outs occur, the low pressure pump-down switch can be delayed. In this case a low pressure safety switch without any delay timer is mandatory.

- While the thermostat is off, the number of pressure switch resets should be limited to avoid short cycling of the compressor. Use dedicated wiring and an additional relay which allows for one shot pump-down.

The pump-down allows to store all the refrigerant in the high pressure side circuit. On unitary or close-coupled systems, where the system refrigerant charge is expected to be both correct and definable the entire system charge may be stored in the condenser during pump-down if all components have been properly sized.

Other application needs a liquid receiver to store the refrigerant.

Receiver dimensioning requires special attention. The receiver shall be large enough to contain part of the system refrigerant charge but it shall not be dimensioned too large. A large receiver easily leads to refrigerant overcharging during maintenance operation.

Liquid flood back

During normal operation, refrigerant enters the compressor as a superheated vapour. Liquid flood back occurs when a part of the refrigerant entering the compressor is still in liquid state.

A continuous liquid flood back will cause oil dilution and, in extreme situations lead to lack of lubrication and high rate of oil leaving the compressor.

Liquid flood back test - Repetitive liquid flood back testing must be carried out under TXV threshold operating conditions: a high pressure ratio and minimum evaporator load, along with the measurement of suction superheat, oil sump temperature and discharge gas temperature.

temperature be less than 35K above the saturated discharge temperature, this indicates liquid flood back.

During operations, liquid flood back may be detected by measuring either the oil sump temperature or the discharge gas temperature. If at any time during operations, the oil sump temperature drops to within 10K or less above the saturated suction temperature, or should the discharge gas

Continuous liquid flood back can occur with a wrong dimensioning, a wrong setting or malfunction of the expansion device or in case of evaporator fan failure or blocked air filters.

A suction accumulator providing additional protection as explained hereunder can be used to solve light continuous liquid flood back.

Suction accumulator: a suction accumulator offers protection against refrigerant flood back at start-up, during operations or defrosting by trapping the liquid refrigerant upstream from the compressor. The suction accumulator also protects against off-cycle migration by providing additional internal free volume to the low side of the system.

A suction accumulator must be carefully dimensioned, taking into account the refrigerant charge as well as the gas velocity in the suction line. Depending on the operating conditions it may happen that the recommended connections of the accumulator are one size smaller than the suction line.

Low ambient application

Low ambient start-up

Under cold ambient conditions (<math><0^{\circ}\text{C}</math>), upon start-up the pressure in the condenser may be so low that a sufficient pressure differential across the expansion device cannot be developed to properly feed the evaporator.

As a result, the compressor may go into a deep vacuum, which can lead to compressor failure due to internal arcing and instability in the scroll wraps. Under no circumstances should the compressor be allowed to operate under vacuum. The low-pressure control must be set in accordance with the table on page 24 in order to prevent this from happening.

Early feeding of the evaporator and management of the discharge pressure could help to attenuate these effects.

Low pressure differentials can also cause the expansion device to «hunt» erratically, which might cause surging conditions within the evaporator, with liquid spillover into the compressor. This effect is most pronounced during low load conditions, which frequently occur during low ambient conditions.

Low ambient operations

It is recommended that the unit be tested and monitored at minimum load and low ambient conditions as well. The following considerations should be taken into account to ensure proper system operating characteristics.

The expansion device should be sized to ensure proper control of the refrigerant flow into the evaporator. An oversized valve may result in erratic control. This consideration is especially important in manifolded units where low load conditions may require the frequent cycling of compressors. This can lead to liquid refrigerant entering the compressor if the expansion valve does not provide stable refrigerant super-heat control under varying loads.

The superheat setting of the expansion device should be sufficient to ensure proper superheat levels during low loading periods. A minimum of 5 K stable superheat is required.

Head pressure control under low ambient conditions: Several possible solutions are available to prevent the risk of compressor to vacuum and low pressure differential between the suction and discharge pressures.

In air-cooled machines, cycling the fans with a head pressure controller will ensure that the fans remain off until the condensing pressure has reached a satisfactory level. Variable speed fans can also be used to control the condensing pressure. In water-cooled units, the same can be performed using a water regulator valve that is also operated by head pressure, thereby ensuring that the water valve does not open until the condensing pressure reaches a satisfactory level.

The minimum condensing pressure must be set at the minimum saturated condensing temperature shown in the application envelopes.

Under very low ambient conditions, in which testing has revealed that the above procedures might not ensure satisfactory condensing and suction pressures, the use of a head pressure control valve is recommended. Note: This solution requires extra refrigerant charge, which can introduce other problems. A non-return valve in the discharge line is recommended and special care should be taken when designing the discharge line.

For further information, please contact Danfoss.

Scroll and reciprocating

Unlike the reciprocating compressor, a scroll doesn't have dead volume. Neither does it have a suction valve causing pressure drop. As a result a scroll compressor has a high volumetric efficiency even at low suction pressure. In systems such as ice makers and milk cooling tanks this high capacity at low temperature shortens the cooling time.

When moving from a reciprocating compressor to a scroll compressor, the selection shall always be made based on cooling capacity at the application rating point. Never make a selection based on equivalent displacement.

Low load operations

The compressor should be run for a minimum period to ensure that the oil has sufficient time to properly return to the compressor sump and that

the motor receives enough cooling under conditions of lowest refrigerant mass flow.

Brazed plate heat exchangers

A brazed plate heat exchanger needs very little internal volume to satisfy the heat transfer requirements. Consequently, the heat exchanger offers very little internal volume for the compressor to draw vapour from the suction side. The compressor can then quickly enter into a vacuum condition. It is therefore important that the expansion device be sized correctly and that a sufficient pressure differential across the expansion device be available to ensure adequate refrigerant feed into the evaporator. This aspect is of special concern when operating the unit under low ambient and load conditions. For further information on these conditions, please refer to the previous sections.

Due to the small volume of the brazed plate heat exchanger, no pump-down cycle is normally required. The suction line running from the heat exchanger to the compressor must be trapped to avoid refrigerant migration to the compressor.

When using a brazed plate condenser heat exchanger, a sufficient free volume for the discharge gas to accumulate is required in order to avoid excess pressure build-up. At least 1 meter of discharge line is necessary to generate this volume. To help reduce the discharge gas volume immediately after start-up, the supply of cooling water to the heat exchanger may be opened before the compressor starts, to remove superheat and condense the incoming discharge gas more quickly.

Water utilising systems

Apart from residual moisture in the system after commissioning, water could also enter the refrigeration circuit during operation. Water in the system shall always be avoided. Not only because it can shortly lead to electrical failure, sludge in sump and corrosion but in particular because it can cause serious safety risks.

Common causes for water leaks are corrosion and freezing.

Corrosion: Materials in the system shall be compliant with water and protected against corrosion.

Freezing: When water freezes into ice its volume expands which can damage heat exchanger walls and cause leaks. During off periods water inside heat exchangers could start freezing when ambient temperature is lower than 0°C. During on periods ice banking could occur when the circuit is running continuously at too low load. Both situations should be avoided by connecting a pressure and thermostat switch in the safety line.

Starting sound level

During start-up transients it is natural for the compressor sound level to be slightly higher than during normal running. MLZ/MLM scroll compressors exhibit very little increased start-up transient sound. If a 3-phase model is miswired, the compressor will run in reverse. Reverse compres-

or rotation is characterized by an objectionable sound. To correct reverse rotation, disconnect power and switch any two of the three power leads at the unit contactor. Never switch leads at the compressor terminals.

Running sound level

MLZ/MLM are designed with features to reduce the sound level when a compressor is running.

Sound levels are at rated (medium temperature) conditions.

Model	50 Hz		60 Hz	
	Sound power (dBA) Without jacket	Sound power (dBA) With jacket	Sound power (dBA) Without jacket	Sound power (dBA) With jacket
MLZ/MLM 015				
MLZ/MLM 019	65	57	68	60
MLZ/MLM 021	65	57	68	60
MLZ/MLM026	67	59	70	62
MLZ/MLM 030	70	62	73	65
MLZ/MLM 038	71	63	74	66
MLZ/MLM 045	71	63	74	66
MLZ/MLM 048	72	64	75	67
MLZ/MLM 058	74	66	77	69
MLZ/MLM 066	74	66	77	69
MLZ/MLM 076	74	66	77	69

Stopping sound level

MLZ/MLM have a unique discharge valve design that minimizes stopping noise. This results in very low shutdown sound.

Sound generation in a refrigeration system

Typical sound and vibration in refrigeration systems encountered by design and service engineers may be broken down into the following three source categories.

Sound radiation: This generally takes an airborne path.

Mechanical vibrations: These generally extend along the parts of the unit and structure.

Gas pulsation: This tends to travel through the cooling medium, i.e. the refrigerant.

The following sections will focus on the causes and methods of mitigation for each of the above sources.

Compressor sound radiation

For sound radiating from the compressor, the emission path is airborne and the sound waves are travelling directly from the machine in all directions.

The MLZ/MLM scroll compressors are designed to be quiet and the frequency of the sound generated is pushed into the higher ranges, which not only are easier to reduce but also do not generate the penetrating power of lower-frequency sound.

Use of sound-insulation materials on the inside of unit panels is an effective means of substantially reducing the sound being transmitted to the outside. Ensure that no components capable of transmitting sound/vibration within the unit come into direct contact with any non insulated parts on the walls of the unit.

Because of the unique design of a full-suction gas & oil cooled motor, compressor body insulation across its entire operating range is possible.

Mechanical vibrations

Vibration isolation constitutes the primary method for controlling structural vibration. MLZ/MLM scroll compressors are designed to produce minimal vibration during operations. The use of rubber isolators on the compressor base plate or on the frame of a manifolded unit is very effective in reducing vibration being transmitted from the compressor(s) to the unit. Rubber grommets are supplied with all MLZ/MLM compressors. Once the supplied rubber grommets have been properly mounted, vibration transmitted from the compressor base plate to the unit are held to

a strict minimum. In addition, it is extremely important that the frame supporting the mounted compressor be of sufficient mass and stiffness to help dampen any residual vibration potentially transmitted to the frame. The tubing should be designed so as to both reduce the transmission of vibrations to other structures and withstand vibration without incurring any damage. Tubing should also be designed for three-dimensional flexibility. For more information on piping design, please see the section entitled "Essential piping design considerations" p. 25.

Gas pulsation

The MLZ/MLM scroll compressors have been designed and tested to ensure that gas pulsation has been minimized for the most commonly encountered refrigeration pressure ratio. On installations where the pressure ratio lies beyond the typical range, testing should be conducted under all ex-

pected conditions and operating configurations to ensure that minimum gas pulsation is present. If an unacceptable level is identified, a discharge muffler with the appropriate resonant volume and mass should be installed. This information can be obtained from the component manufacturer.

Each MLZ/MLM compressor is shipped with printed Instructions for installation. These Instructions can also be downloaded from our web site

www.danfoss.com or directly from:
<http://instructions.cc.danfoss.com>

System cleanliness

The refrigeration system, regardless of the type of compressor used, will only provide high efficiency and good reliability, along with a long operating life, if the system contains solely the refrigerant and oil it was designed for. Any other substances within the system will not improve performance and, in most cases, will be highly detrimental to system operations.

small enough to pass through a mesh screen and can cause considerable damage within a bearing assembly. The use of highly hygroscopic PVE oil in MLZ compressors requires that the oil be exposed to the atmosphere just as little as possible.

The presence of non-condensable substances and system contaminants, such as metal shavings, solder and flux, have a negative impact on compressor service life. Many of these contaminants are

During the manufacturing process, circuit contamination may be caused by:

- Brazing and welding oxides,
- Filings and particles from the removal of burrs in pipe-work,
- Brazing flux,
- Moisture and air.

Compressor handling and storage

Compressors are provided with a lifting lug. This lug should always be used to lift the compressor. Once the compressor is installed, the lifting lug should never be used to lift the complete installation. The compressor must be handled with

caution in the vertical position, with a maximum inclination of 15° from vertical. Store the compressor between -35°C and 55°C, not exposed to rain or corrosive atmosphere.

Compressor mounting

Maximum inclination from the vertical plane, while operating must not exceed 7 degrees. All compressors are delivered with 4 rubber grommets

and metal sleeves. Compressors must always be mounted with these grommets. Recommended torque for mounting bolts: 11 Nm (±1 Nm).

Compressor holding charge

Each compressor is shipped with a nominal dry nitrogen holding charge between 0.4 bar and 0.7 bar, and is sealed with elastomer plugs. The plugs should be removed with care to avoid oil loss when the holding charge is released. Remove the suction plug first and the discharge plug af-

terwards. The plugs shall be removed only just before connecting the compressor to the installation in order to avoid moisture entering the compressor. When the plugs are removed, it is essential to keep the compressor in an upright position to avoid oil spillage.

Tube brazing procedure

Do not bend the compressor discharge or suction lines or force system piping into the compressor connections, because this will increase

stresses that are a potential cause of failure. Recommended brazing procedures and material, are described on following page.

Brazing material

For copper suction and discharge fittings, use copper-phosphorus brazing material. Sil-Fos® and other silver brazing materials are also accept-

able. If flux is required for the brazing operation, use coated rod or flux core wire. To avoid system contamination, do not brush flux on.

Compressor connection

When brazing the compressor fittings, do not overheat the compressor shell, which could severely damage certain internal components due to excessive heating. Use of a heat shield and/or a heat-absorbent compound is highly recommended. For brazing the suction and discharge connections, the following procedure is advised:

- Make sure that no electrical wiring is connected to the compressor.
- Protect the terminal box and compressor painted surfaces from torch heat damage (see diagram).
- Use only clean refrigeration-grade copper tubing and clean all connections.
- Purge nitrogen through the compressor in order to prevent against oxidation and flammable conditions. The compressor should not be exposed to the open air for extended periods.
- Use of a double-tipped torch is recommended.
- Apply heat evenly to area **A** until the brazing temperature is reached. Move the torch to area **B** and apply heat evenly until the brazing temperature has been reached there as well, and then begin adding the brazing material. Move the torch evenly around the joint, in applying only enough brazing material to flow the full circumference of the joint.
- Move the torch to area **C** only long enough to draw the brazing material into the joint, but not into the compressor.
- Remove all remaining flux once the joint has been soldered with a wire brush or a wet cloth. Remaining flux would cause corrosion of the tubing.

Ensure that no flux is allowed to enter into the tubing or compressor. Flux is acidic and can cause substantial damage to the internal parts of the system and compressor.

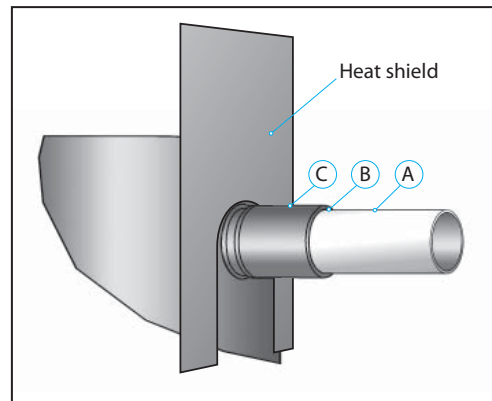

The PVE oil used in MLZ compressors is highly hygroscopic and will rapidly absorb moisture from the air. The compressor must therefore not be left open to the atmosphere for a long period of time. The compressor fitting plugs shall be removed just before brazing the compressor.

⚠ Before eventual unbrazing the compressor or any system component, the refrigerant charge must be removed from both the high and low pressure sides. Failure to do so may result in serious personal injury. Pressure gauges must be used to ensure all pressures are at atmospheric level.

For more detailed information on the appropriate materials required for brazing or soldering, please contact the product manufacturer or distributor. For specific applications not covered herein, please contact Danfoss for further information.

Vacuum evacuation and moisture removal

Moisture obstructs the proper functioning of the compressor and the refrigeration system.

Air and moisture reduce service life and increase condensing pressure, and cause excessively high discharge temperatures, which can destroy the lubricating properties of the oil. Air and moisture also increase the risk of acid formation, giving rise to copper plating. All these phenomena can cause mechanical and electrical compressor failure.

For these reasons it's important to perform a vacuum dehydration on the system to remove all residual moisture from the pipe-work after assembly;

MLZ and MLM compressors are delivered with < 100 ppm moisture level. The required moisture level in the circuit after vacuum dehydration must be < 100 ppm for systems with an MLZ and < 300 ppm for systems with an MLM compressor.

- Never use the compressor to evacuate the system.
- Connect a vacuum pump to both the LP & HP sides.
- Evacuate the system to a pressure of 500 µm Hg (0.67 mbar) absolute.
- Do not use a megohm meter nor apply power to the compressor while it's under vacuum as this may cause internal damage.

Liquid line filter driers

A properly sized & type of drier is required. Important selection criteria include the driers water content capacity, the system refrigeration capacity, and the system refrigerant charge. The drier must be able to reach and maintain a moisture level of 50 ppm end point dryness (EPD). Danfoss recommends DCL (solid core) driers for the MLM compressor (R22 with Alkylbenzene) and DML (100% molecular sieve) driers for MLZ compressors (R404A, R507, R134a, R22) with PVE oil.

For servicing of existing installations where acid formation may be present, the Danfoss DCL solid core filter drier containing activated alumina is recommended.

After burn out, remove & replace the liquid line filter drier and install a Danfoss type DAS burn-out drier of the appropriate capacity. Refer to the DAS drier instructions and technical information for correct use of the burnout drier on the liquid line.

Refrigerant charging

It is recommended that system charging be done using the weighed charge method, adding refrigerant to the high side of the system. Charging the high and low sides of a system with gas simultaneously at a controlled rate is also an acceptable method. Do not exceed the recommended unit charge, and never charge liquid to the low side.

Vacuum or charge from one side can seal the scrolls and result in a non-starting compressor. When servicing, always ensure that LP/HP pressures are balanced before starting the compressor.

Be sure to follow all government regulations regarding refrigerant reclamation and storage.

Insulation resistance and dielectric strength

Insulation resistance must be higher than 1 megohm when measured with a 500 volt direct current megohm tester.

leakage current readings. Such readings do not indicate a faulty compressor, and should not be cause for concern.

Each compressor motor is tested at the factory with a high potential voltage (hi-pot) that exceeds the UL requirement both in potential and in duration. Leakage current is less than 0.5 mA.

In testing insulation resistance, Danfoss recommends that the system be first operated briefly to distribute refrigerant throughout the system. Following this brief operation, retest the compressor for insulation resistance or current leakage.

MLZ/MLM scroll compressors are configured with the pump assembly at the top of the shell, and the motor below. As a result, the motor can be partially immersed in refrigerant and oil. The presence of refrigerant around the motor windings will result in lower resistance values to ground and higher

Never reset a breaker or replace a fuse without first checking for a ground fault (a short circuit to ground). Be alert for sounds of arcing inside the compressor.

Packaging

Single pack

Compressors are packed individually in a cardboard box. They can be ordered in any quantity. Minimum ordering quantity = 1. As far as possible, Danfoss will ship the boxes on full pallets of 6 or 9 compressors according below table.

- Each box also contains following accessories:
- 4 grommets
- 4 assemblies of self tapping US thread bolts, washers and sleeves
- 4 additional sleeves
- 1 screw for earth connection
- Depending on model and shipping type a run capacitor may be included (see table).

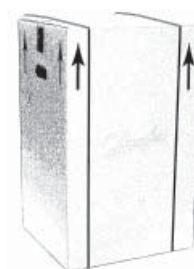

Industrial pack

Compressors are not packed individually but are shipped all together on one pallet. They can be ordered in quantities of full pallets only, multiples of 12 or 16 compressors, according below table.

Each industrial pack pallet contains following accessories:

- 4 grommets per compressor
- 4 sleeves per compressor

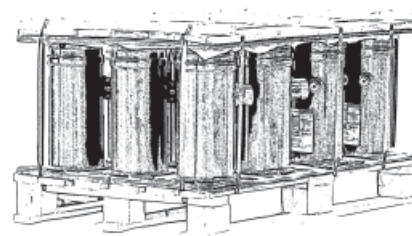

Packaging details

		US pallets Optimized for overseas container loading		Danfoss pallets Optimized for overseas container loading & European storage racks	
Code number		120U....		121U....	
Pack type		Industrial pack	Single pack	Industrial pack	Single pack
Compressors per pallet		16	9*	12	6*
Static stacking of pallets**		4	4	4	4
Shipped accessories	Run capacitor (for single phase models)	Not included	Not included	Not included	Included
	Screw for earth connection	Not included	Included	Included	Included
	4 grommets per compressor	Included	Included	Included	Included
	4 assemblies of self tapping US thread bolt + washer + sleeve per compressor	Not included	Included	Not included	Included
	4 extra sleeves per compressor	Included	Included	Included	Included

* Quantity for full pallets. Single packs can be ordered per 1.

** Stacking only allowed for full pallets with identical products per pallet

	Compressors	Model variation	Connections	Features	Single pack				Industrial pack				
					code 1	code 2	code 4	code 5	code 1	code 2	code 4	code 5	
MLZ models	US pallet	MLZ015	T	P	9	120U8058	120U8036	120U8002	120U8024	120U8057	120U8035	120U8001	120U8023
		MLZ019	T	P	9	120U8060	120U8038	120U8004	120U8026	120U8059	120U8037	120U8003	120U8025
		MLZ021	T	P	9	120U8062	120U8040	120U8006	120U8028	120U8061	120U8039	120U8005	120U8027
		MLZ026	T	P	9	120U8064	120U8042	120U8008	120U8030	120U8063	120U8041	120U8007	120U8029
		MLZ030	T	C	9	120U8066	120U8044	120U8010	120U8032	120U8065	120U8043	120U8009	120U8031
		MLZ038	T	C	9	120U8068	120U8046	120U8012	120U8034	120U8067	120U8045	120U8011	120U8033
		MLZ045	T	C	9		120U8048	120U8014			120U8047	120U8013	
		MLZ048	T	C	9		120U8050	120U8016			120U8049	120U8015	
		MLZ058	T	C	9		120U8052	120U8018			120U8051	120U8017	
		MLZ066	T	C	9		120U8054	120U8020			120U8053	120U8019	
	MLZ076	T	C	9		120U8056	120U8022			120U8055	120U8021		
	Danfoss pallet	MLZ015	T	P	9	121U8058	121U8036	121U8002	121U8024	121U8057	121U8035	121U8001	121U8023
		MLZ019	T	P	9	121U8060	121U8038	121U8004	121U8026	121U8059	121U8037	121U8003	121U8025
		MLZ021	T	P	9	121U8062	121U8040	121U8006	121U8028	121U8061	121U8039	121U8005	121U8027
		MLZ026	T	P	9	121U8064	121U8042	121U8008	121U8030	121U8063	121U8041	121U8007	121U8029
		MLZ030	T	C	9	121U8066	121U8044	121U8010	121U8032	121U8065	121U8043	121U8009	121U8031
		MLZ038	T	C	9	121U8068	121U8046	121U8012	121U8034	121U8067	121U8045	121U8011	121U8033
		MLZ045	T	C	9		121U8048	121U8014			121U8047	121U8013	
		MLZ048	T	C	9		121U8050	121U8016			121U8049	121U8015	
		MLZ058	T	C	9		121U8052	121U8018			121U8051	121U8017	
MLZ066		T	C	9		121U8054	121U8020			121U8053	121U8019		
MLZ076	T	C	9		121U8056	121U8022			121U8055	121U8021			
MLM models	US pallet	MLM015	T	P	9		120U8106	120U8072	120U8094		120U8105	120U8071	120U8093
		MLM019	T	P	9		120U8108	120U8074	120U8096		120U8107	120U8073	120U8095
		MLM021	T	P	9		120U8110	120U8076	120U8098		120U8109	120U8075	120U8097
		MLM026	T	P	9		120U8112	120U8078	120U8100		120U8111	120U8077	120U8099
		MLM030	T	C	9		120U8114	120U8080	120U8102		120U8113	120U8079	120U8101
		MLM038	T	C	9		120U8116	120U8082	120U8104		120U8115	120U8081	120U8103
		MLM045	T	C	9		120U8118	120U8084			120U8117	120U8083	
		MLM048	T	C	9		120U8120	120U8086			120U8119	120U8085	
		MLM058	T	C	9		120U8122	120U8088			120U8121	120U8087	
		MLM066	T	C	9		120U8124	120U8090			120U8123	120U8089	
		MLM076	T	C	9		120U8126	120U8092			120U8125	120U8091	

Run capacitors for PSC wiring



Type	Code n°	Description	Application	Packaging	Pack size
70 µF	120Z0051	PSC wiring Run Capacitor 70 µF, motor voltage code 5 - 220-240V / 1 / 50Hz	MLZ015-019-021-026	Multipack	10
50 µF	8173233	PSC wiring Run Capacitor 50 µF, motor voltage code 5 - 220-240V / 1 / 50Hz	MLZ030	Multipack	10
55 µF	8173234	PSC wiring Run Capacitor 55 µF, motor voltage code 5 - 220-240V / 1 / 50Hz	MLZ038-045-048	Multipack	10

Start capacitors and starting relay for CSR wiring



Type	Code n°	Description	Application	Packaging	Pack size
145-175 µF	120Z0399	CSR wiring Start Capacitor 145-175 µF, motor voltage code 5 - 220-240V / 1 / 50Hz	MLZ015-019-021-026	Multipack	10
161-193 µF	120Z0040	CSR wiring Start Capacitor 161-193 µF, motor voltage code 5 - 220-240V / 1 / 50Hz	MLZ030	Multipack	10
88-108 µF	8173001	CSR wiring Start Capacitor 88-108 µF, motor voltage code 5 - 220-240V / 1 / 50Hz	MLZ038-045-048	Multipack	10
RVA9CKL	120Z0393	CSR wiring Starting Relay, motor voltage code 5 - 220-240V / 1 / 50Hz	MLZ015-019-021-026	Multipack	10
RVA3EKL	120Z0394	CSR wiring Starting Relay, motor voltage code 5 - 220-240V / 1 / 50Hz	MLZ030	Multipack	10
RVA4GKL	120Z0395	CSR wiring Starting Relay, motor voltage code 5 - 220-240V / 1 / 50Hz	MLZ038-045-048	Multipack	10

Rotolock adaptor set

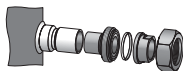

Type	Code n°	Description	Application	Packaging	Pack size
	120Z0126	Rotolock adaptor set (1-1/4" ~ 3/4"), (1" ~ 1/2")	MLZ 015-019-021-026	Multipack	6
	120Z0127	Rotolock adaptor set (1-1/4" ~ 7/8"), (1" ~ 1/2")	MLZ 030-038-045	Multipack	6
	120Z0128	Rotolock adaptor set (1-1/4" ~ 7/8"), (1-1/4" ~ 3/4")	MLZ 048	Multipack	6
	120Z0129	Rotolock adaptor set (1-3/4" ~ 1-1/8"), (1-1/4" ~ 7/8")	MLZ 058-066-076	Multipack	6

Rotolock adaptor



Type	Code n°	Description	Application	Packaging	Pack size
	120Z0366	Rotolock adaptor (1-1/4" ~ 3/4")	MLZ 015-019-021-026 suction	Multipack	10
	120Z0367	Rotolock adaptor (1-1/4" ~ 7/8")	MLZ 030-038-045-048 suction	Multipack	10
	120Z0364	Rotolock adaptor (1-3/4" ~ 1-1/8")	MLZ 058-066-076 suction	Multipack	10
	120Z0365	Rotolock adaptor (1" ~ 1/2")	MLZ 015-019-021-026-030-038-045 discharge	Multipack	10
	120Z0366	Rotolock adaptor (1-1/4" ~ 3/4")	MLZ 048 discharge	Multipack	10
	120Z0367	Rotolock adaptor (1-1/4" ~ 7/8")	MLZ 058-066-076 discharge	Multipack	10

Crankcase heater



Type	Code No	Description	Application	Packaging	Pack Size
	120Z5040	Belt type crankcase heater, 70 W, 240 V, CE mark, UL (Wire length: 1270 mm)	MLZ/MLM 015-019-021-026-030-038-045-048-058-066-076	Multipack	4
	120Z5041	Belt type crankcase heater, 70 W, 400/460 V, CE mark, UL (Wire length: 1270 mm)	MLZ/MLM 015-019-021-026-030-038-045-048-058-066-076	Multipack	4
	120Z5042	Belt type crankcase heater, 70 W, 575 V, CE mark, UL (Wire length: 1270 mm)	MLZ/MLM 015-019-021-026-030-038-045-048-058-066-076	Multipack	4
	120Z0059	Belt type crankcase heater, 65 W, 230V, CE mark, UL (Wire length: 1000 mm)	MLZ/MLM 030-038-045-048-058-066-076	Multipack	6
	120Z0060	Belt type crankcase heater, 65 W, 400 V, CE mark, UL (Wire length: 1000 mm)	MLZ/MLM 030-038-045-048-058-066-076	Multipack	6

Discharge temperature protection



Type	Code No	Description	Application	Packaging	Pack Size
	7750009	Discharge thermostat kit	All models	Multipack	10
	7973008	Discharge thermostat kit	All models	Industry pack	50

Lubricant



Type	Code No	Description	Application	Packaging	Pack Size
320HV	120Z5034	PVE lubricant, 0.95 litre can	MLZ	Single pack	1

Mounting hardware



Type	Code No	Description	Application	Packaging	Pack Size
	120Z5017	Mounting grommet	All models	Single pack	1
	120Z5014	Mounting sleeve	All models	Single pack	1
	120Z5031	Mounting kit, including 1 bolt, 1 sleeve, 1 washer	All models	Single pack	1
	120Z5005	Mounting kit for 1 scroll compressor including 4 grommets, 4 sleeves, 4 bolts, 4 washers	All models	Single pack	1



The Danfoss product range for the refrigeration and air conditioning industry

Danfoss Refrigeration & Air Conditioning is a worldwide manufacturer with a leading position in industrial, commercial and supermarket refrigeration as well as air conditioning and climate solutions.

We focus on our core business of making quality products, components and systems that enhance performance and reduce total life cycle costs – the key to major savings.



Controls for Commercial Refrigeration



Controls for Industrial Refrigeration



Electronic Controls & Sensors



Industrial Automation



Household Compressors



Commercial Compressors



Sub-Assemblies



Thermostats



Brazen plate heat exchanger

We are offering a single source for one of the widest ranges of innovative refrigeration and air conditioning components and systems in the world. And, we back technical solutions with business solution to help your company reduce costs, streamline processes and achieve your business goals.

Danfoss A/S • www.danfoss.com

Danfoss Commercial Compressors <http://cc.danfoss.com>